

MANUAL

GOBLIN 700 RAW NITRO

OBLIN

RAW



SAB HELI DIVISION

! Please read this user manual carefully, it contains instructions for the correct assembly of the model.
Please refer to the web site www.goblin-helicopter.com for updates and other important information.

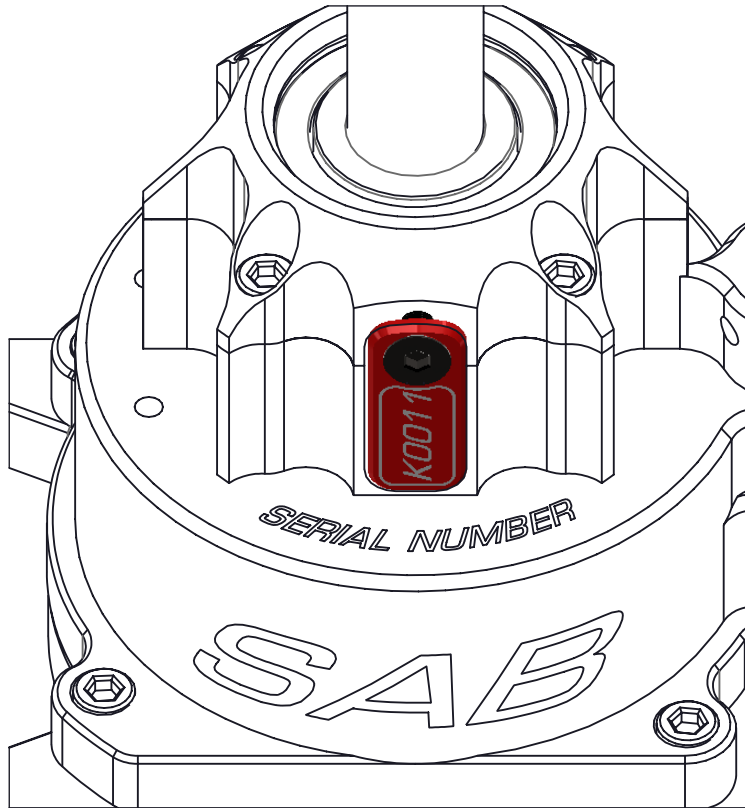

VERY IMPORTANT

You will find your serial number on the RED plate of the transmission module and on the product card included with your kit.
Please take a moment to register your kit online via our web site at:

<http://www.goblin-helicopter.com>

It is extremely important that you take a moment to register your helicopter with us. This is the only way to ensure that you are properly informed about changes to your kit, such as upgrades, retrofits and other important developments. SAB Heli Division cannot be held responsible for any issues with your model and will not provide support unless you register your model.

The Serial number is also engraved in the Aluminum part.

Thank you for your purchase, we hope you enjoy your new Goblin helicopter!

SAB Heli Division

INDEX

- 1 – INTRODUCTION
- 2 – IMPORTANT NOTES**
- 3 – NOTE FOR ASSEMBLY
- 4 – CARBON ROD ASSEMBLY
- 5 – TRANSMISSION GROUP ASSEMBLY
- 6 – SWASHPLATE SERVOS ASSEMBLY
- 7 – FRAME GROUP ASSEMBLY
- 8 – HEAD ASSEMBLY

- 9 – ASSEMBLING OF THE MODULES
- 10 – TENSIONER ASSEMBLY
- 11 – LOWER SIDE FRAME INSTALLATION
- 12 – LANDING GEAR INSTALLATION
- 13 – ENGINE UNIT ASSEMBLY
- 14 – TAIL GROUP ASSEMBLY
- 15 – TAIL BOOM ASSEMBLY
- 16 – TANK ASSEMBLY

- 17 – INSTALLATION BATTERY/FBL/RX
- 18 – INSTALLATION CANOPY
- 19 – IN FLIGHT**
- 20 – MAINTENANCE
- 21 – TRANSMISSION MODULE
- 22 – CHECK LIST**
- 23 – SPARE PARTS

GOBLIN RAW NITRO TECHNICAL SPECIFICATIONS

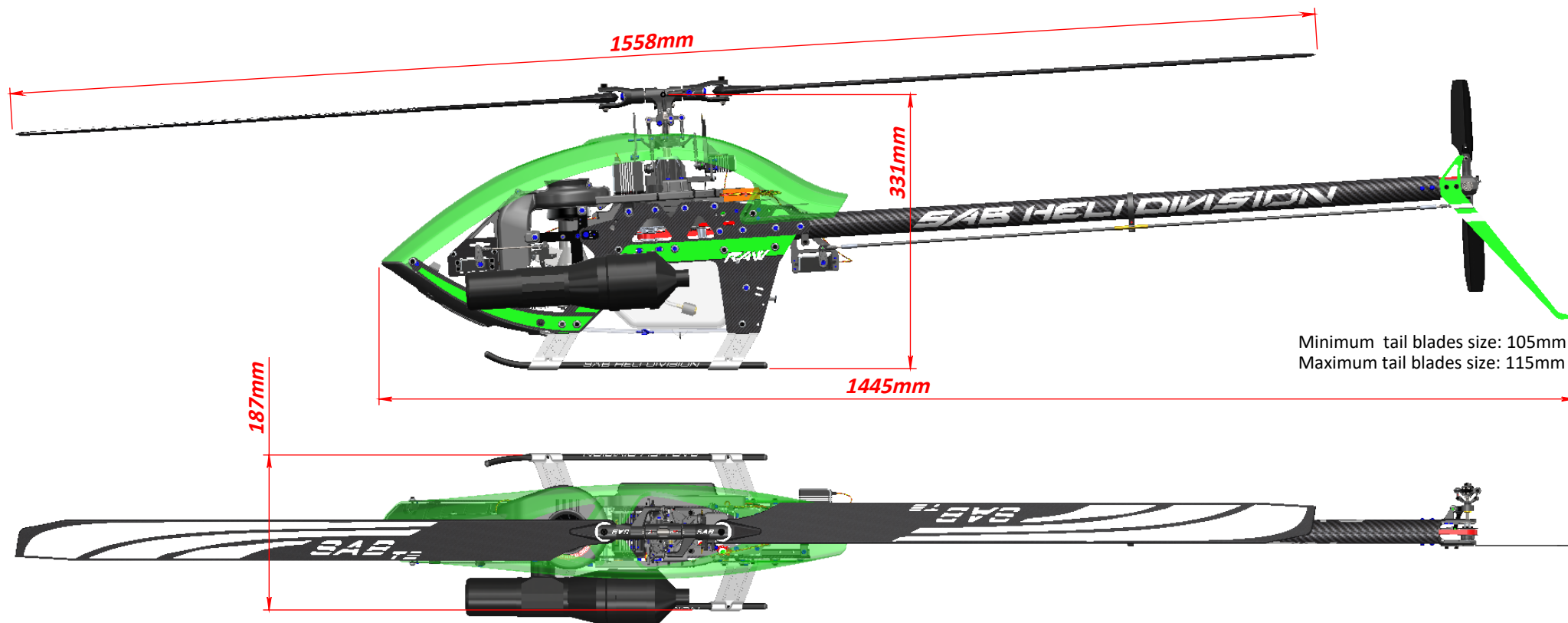

Minimum tail blades size: 105mm
Maximum tail blades size: 115mm

- **RTF Approx. Weight:** 4000 g (RTF no fuel).
- **Main blade length:** 650mm to 720mm (690mm included).
- **Tail blade length:** 105 to 115 mm (105mm included).
- **Main rotor diameter:** 1558 mm (with 690 mm blades).
- **Tail rotor diameter:** 284 mm (with 105 mm tail blades).
- **Engine:** .90 to .105 Nitro Heli Engine.
- **Cyclic Servos:** Standard size 40mm.
- **Tail Servo:** Standard size 40mm.
- **Throttle Servo:** Mini size 35 mm or Standard size 40mm.
- **Main Rotor Ratio:** 7.7- 8.3 :1 (27T included: 8:1).
- **Tail Rotor Ratio :** 5.1 - 4.9:1 (22T included: 5.1:1).
- **Tank Capacity:** 650ml.
- **RX Battery Size:** 2S-1800 / 2500 mAh.

IMPORTANT NOTES

- *This radio controlled helicopter is not a toy.
- *This radio controlled helicopter can be very dangerous.
- *This radio controlled helicopter is a technically complex device which has to be built and handled very carefully.
- *This radio controlled helicopter must be built following these instructions. This manual provides the necessary information to correctly assemble the model.
It is necessary to carefully follow all the instructions.
- *Inexperienced pilots must be monitored by expert pilots.
- *All operators must wear safety glasses and take appropriate safety precautions.
- *A radio controlled helicopter must only be used in open spaces without obstacles, and far enough from people to minimize the possibility of accidents or of injury to property or persons.
- *A radio controlled helicopter can behave in an unexpected manner, causing loss of control of the model, making it very dangerous.
- *Lack of care with assembly or maintenance can result in an unreliable and dangerous model.

***Neither SAB Heli Division nor its agents have any control over the assembly, maintenance and use of this product. Therefore, no responsibility can be traced back to the manufacturer. You hereby agree to release SAB Heli Division from any responsibility or liability arising from the use of this product.**

SAFETY GUIDELINES

- *Fly only in areas dedicated to the use of model helicopters.
- *Follow all control procedures for the radio frequency system.
- *It is necessary that you know your radio system well. Check all functions of the transmitter before every flight.
- *The blades of the model rotate at a very high speed; be aware of the danger they pose and the damage they may cause.
- *Never fly in the vicinity of other people.

DAMAGE LIMITS

SAB HELI DIVISION SHALL NOT BE LIABLE FOR SPECIAL, INDIRECT OR CONSEQUENTIAL DAMAGES, LOSS OF PROFITS OR PRODUCTION OR COMMERCIAL LOSS IN ANY WAY CONNECTED WITH THE PRODUCT, WHETHER SUCH CLAIM IS BASED IN CONTRACT, WARRANTY, NEGLIGENCE, OR STRICT LIABILITY. Further, in no event shall the liability of SAB Heli Division exceed the individual price of the Product on which liability is asserted. As SAB Heli Division has no control over use, setup, final assembly, modification or misuse, no liability shall be assumed nor accepted for any resulting damage or injury. By the act of use, setup or assembly the user accepts all resulting liability. If you as the Purchaser or user are not prepared to accept the liability associated with the use of this Product, you are advised to return this Product immediately in new and unused condition to the place of purchase.

LIMITED WARRANTY

SAB Heli Division reserves the right to change or modify this warranty without notice and disclaims all other warranties, express or implied.

- (a)** This warranty is limited to the original Purchaser (“Purchaser”) and is not transferable. REPLACEMENT AS PROVIDED UNDER THIS WARRANTY IS THE EXCLUSIVE REMEDY OF THE PURCHASER. This warranty covers only those Products purchased from an authorized SAB Heli Division dealer. Third party transactions are not covered by this warranty. Proof of purchase is required for warranty claims.
- (b)** Limitations- SAB HELI DIVISION MAKES NO WARRANTY OR REPRESENTATION, EXPRESS OR IMPLIED, ABOUT NONINFRINGEMENT, MERCHANTABILITY OR FITNESS FOR A PARTICULAR PURPOSE OF THE PRODUCT. THE PURCHASER ACKNOWLEDGES THAT THEY ALONE HAVE DETERMINED THAT THE PRODUCT WILL SUITABLY MEET THE REQUIREMENTS OF THE PURCHASER’S INTENDED USE.
- (c)** Purchaser Remedy- SAB Heli Division’s sole obligation hereunder shall be that SAB Heli Division will, at its option, replace any Product determined by SAB Heli Division to be defective. In the event of a defect, this is the Purchaser’s exclusive remedy. Replacement decisions are at the sole discretion of SAB Heli Division. This warranty does not cover cosmetic damage or damage due to acts of God, accident, misuse, abuse, negligence, commercial use, or modification of or to any part of the Product. This warranty does not cover damage due to improper installation, operation, maintenance or attempted repair by anyone.

NOTE FOR ASSEMBLY



ADDITIONAL COMPONENTS REQUIRED

- *Engine: .90 to .105 Nitro Heli Engine.
- *Muffler suited for the engine being used.
- *Batteries: 2S/1800-2500mAh.
- *Governor unit.
- *1 flybarless 3 axis control unit
- *Radio power system.
- *1 throttle servo (Mini Size).
- *3 cyclic servos (Standard Size).
- *1 tail rotor servo (Standard Size).
- *6 channel radio control system on 2.4 GHz
- *Fuel.

TOOLS, LUBRICANTS, ADHESIVES



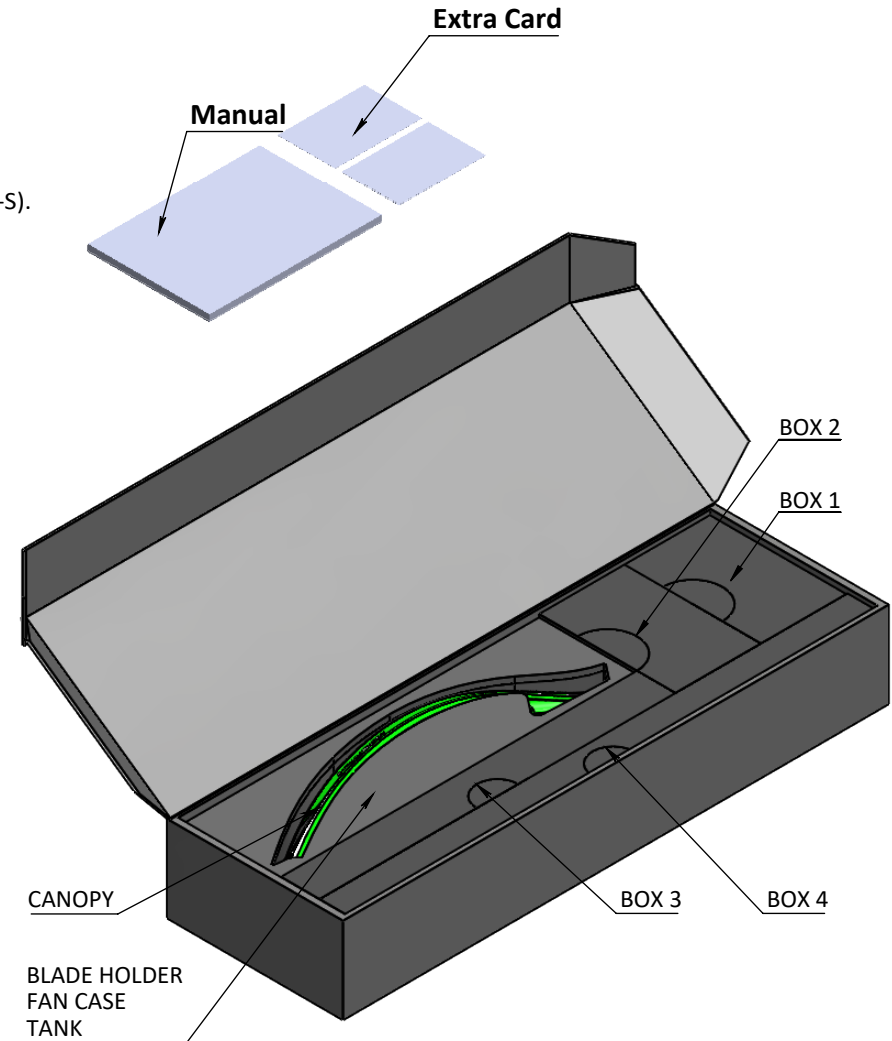

- *Generic pliers.
- *Hexagonal driver, size 1.5, 2, 2.5, 3mm.
- *4/5mm T-Wrench.
- *5.5mm Socket wrench (for M3 nuts).
- *8mm Hex fork wrench (for M5 nuts).
- *Medium threadlocker (SAB p/n HA116-S).
- *Strong retaining compound (SAB p/n HA115-S).
- *Spray lubricant (eg. Try-Flow Oil).
- *Synthetic grease (eg. Microlube 261).
- *Cyanoacrylate adhesive.
- *Pitch Gauge (for set-up).
- *Soldering equipment (for Engine wiring).

INSIDE THE MAIN BOX THERE ARE:

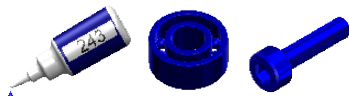
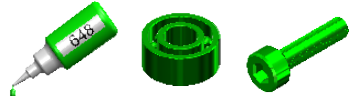

NOTES FOR ASSEMBLY

Please refer to this manual for assembly instructions for this model. Follow the order of assembly indicated. The instructions are divided into chapters, which are structured in a way that each step is based on the work done in the previous step. Changing the order of assembly may result in additional or unnecessary steps. Use thread lockers and retaining compounds as indicated. In general, each bolt or screw that engages with a metal part requires thread lock. It is necessary to pay attention to the symbols listed below:

 <p>Important</p>	 <p>Blue screw and blue bearing in the illustration means you need to use: Thread Locker Medium Strength (SAB HA116-S)</p>	 <p>Green screw and Green bearing in the illustration means you need to use: Use retaining compound (SAB HA115-S)</p>
 <p>Indicates that for this assembly phase you need materials that are: BOX xxx, BAG xxx.</p>	 <p>Use CA Glue</p>	 <p>Use Proper Lubricant</p>

The assembly process is described in the following chapters. Each chapter provides you with the box, bag and/or foam numbers you will need for that chapter. The information is printed in a black box in the upper corner of the page.

BOX 4, BAG FOR PAGE 5

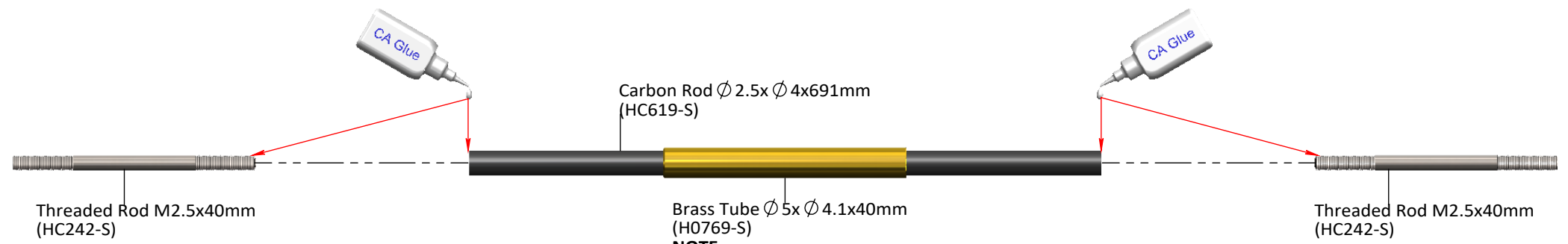

NOTE:

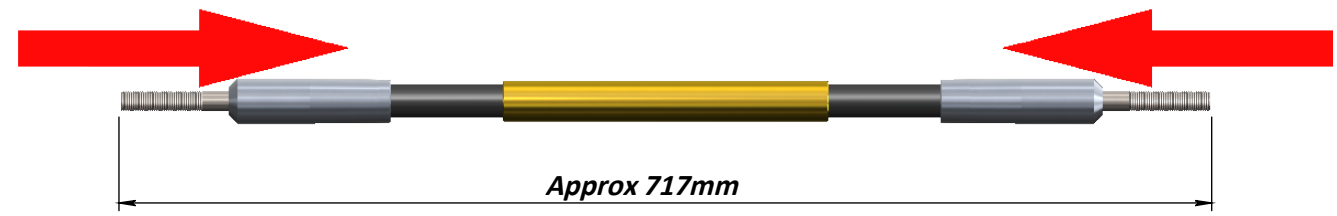
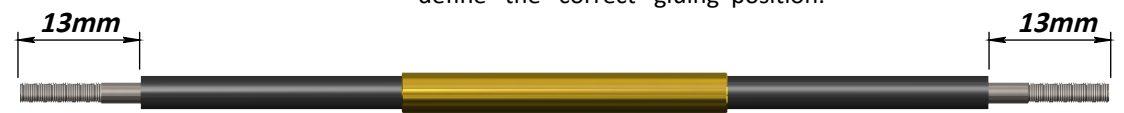

TRANSMISSION GROUP ASSEMBLED AND VERIFIED

The unit is ready to use
Check page 39 for more information.

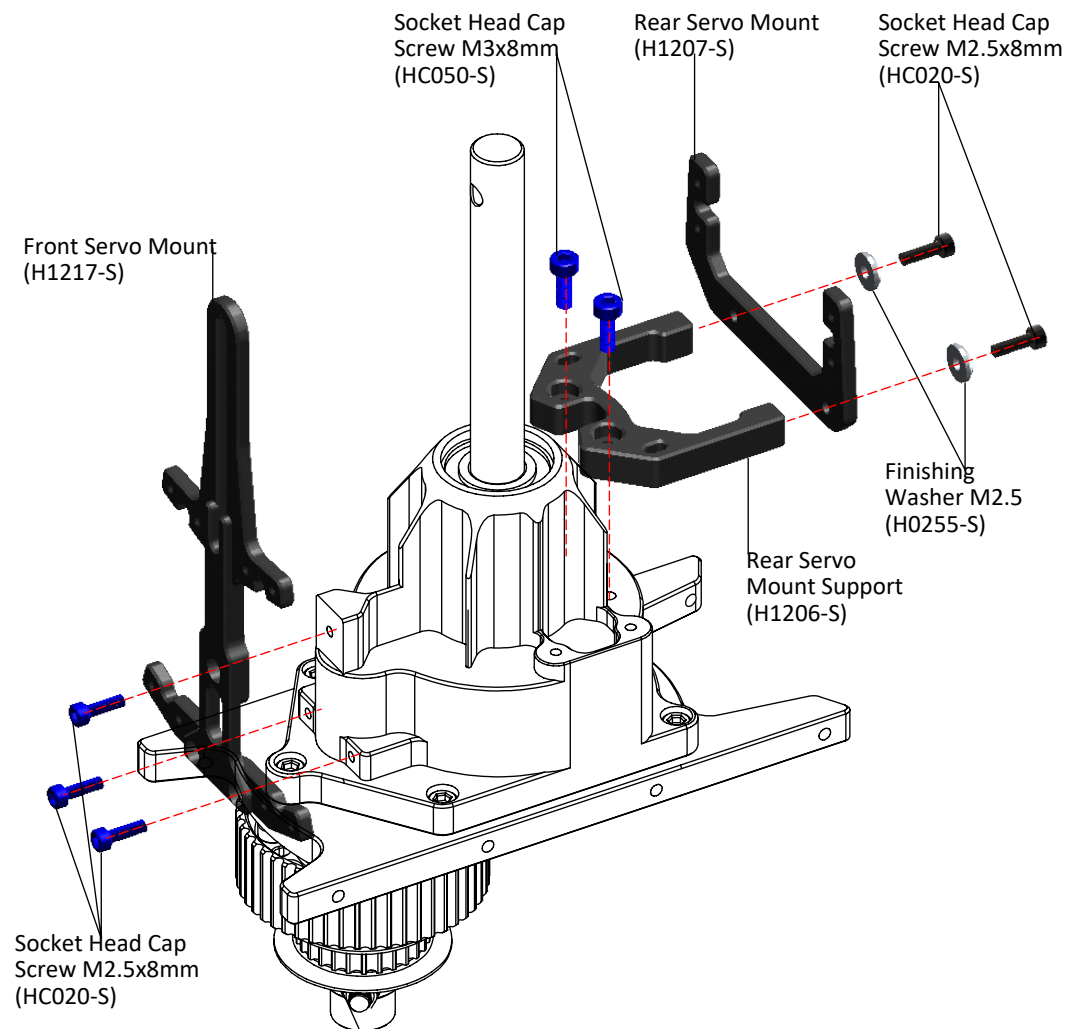
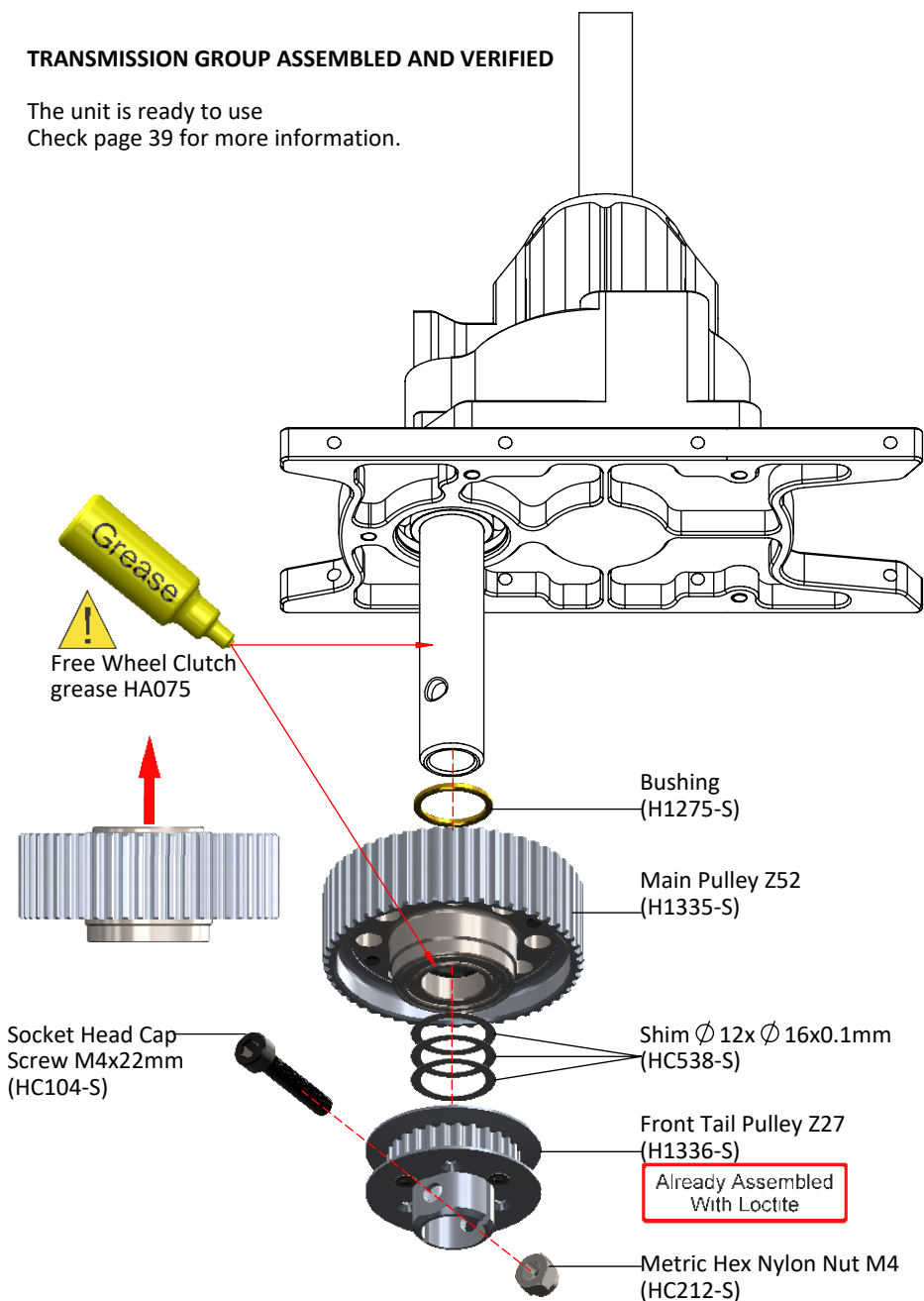

BOX 1, BAG FOR PAGE 7

SERVO ASSEMBLY

The linkage ball must be positioned 18 mm out on the servo arm. The recommended servo arm to use is: SAB p/n [HA050/HA051].

Ensure the alignment of the servo arms (and sub trim is set) before installation of the servos in the model.

Proceed with installation following the instructions below. You can use the G10 servo tool to align the front servo arms with the theoretical horizontal line. **(Figure 3)**

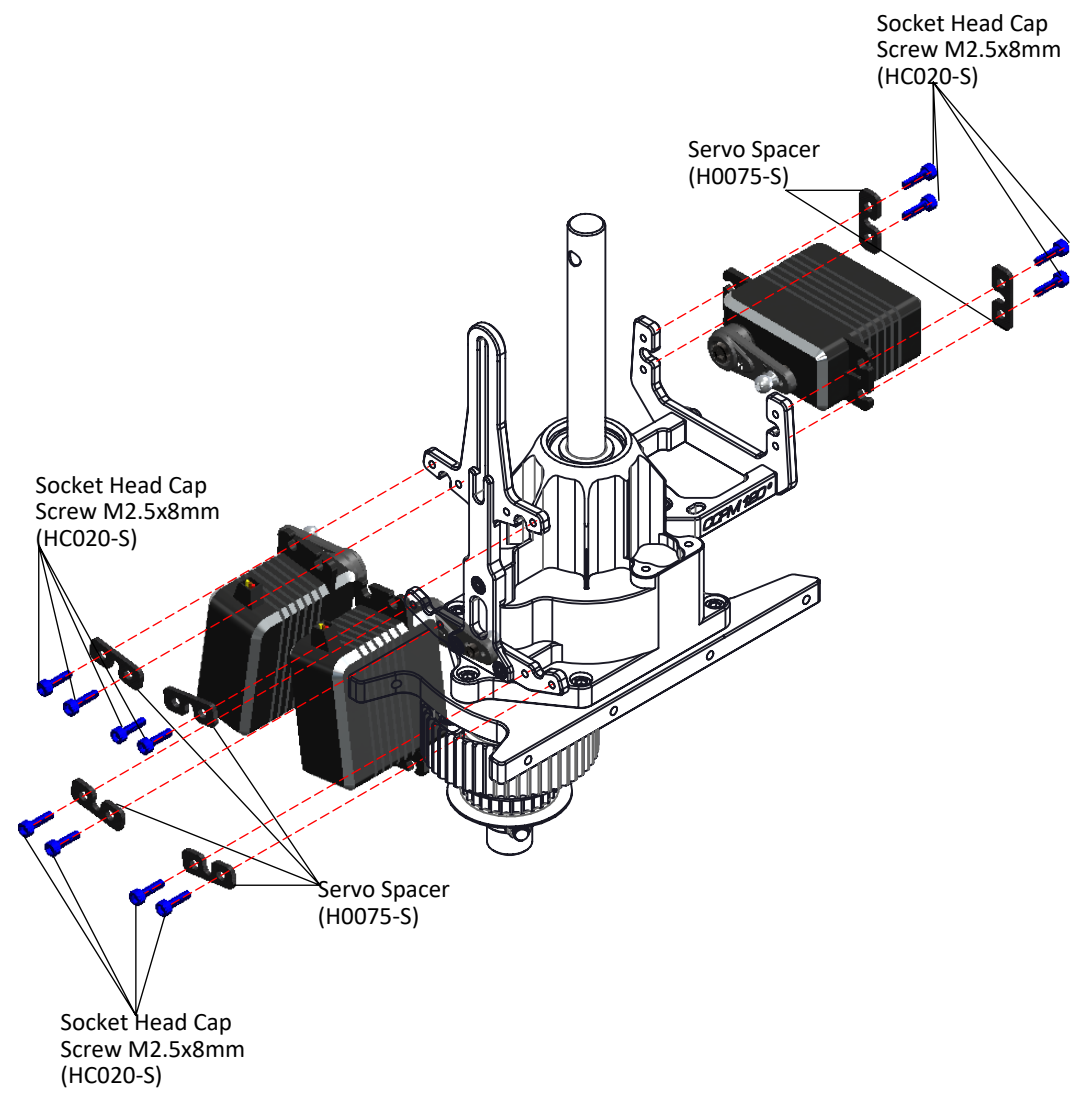
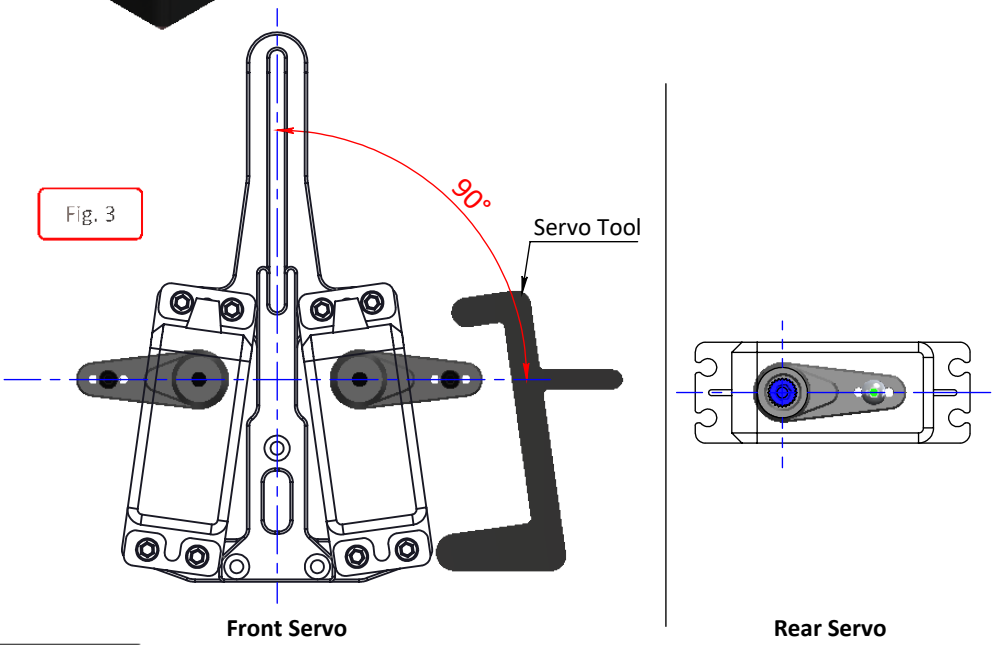

CARBON FRAME

The manufacturing process of the carbon parts often leaves micro-burrs and sharp edges. We recommend de-burring the edges to minimize the risks of electrical wire cuts, etc. **Very important in red line zone.**

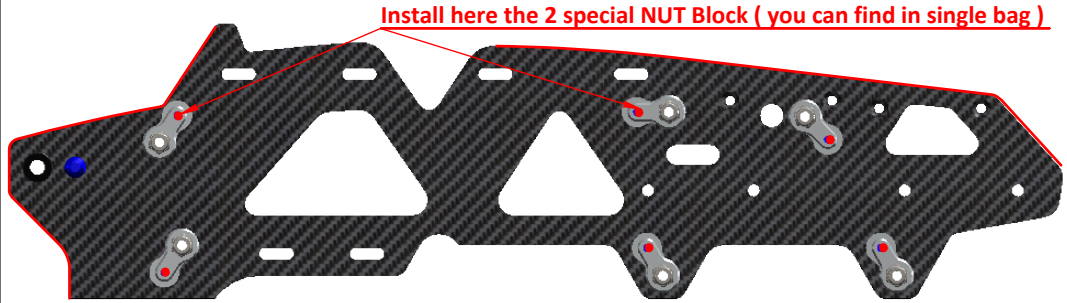
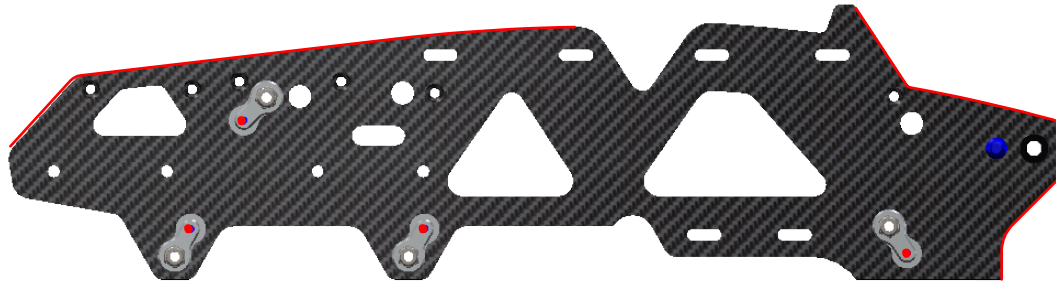

LEFT UPPER MAIN FRAME ASSEMBLY

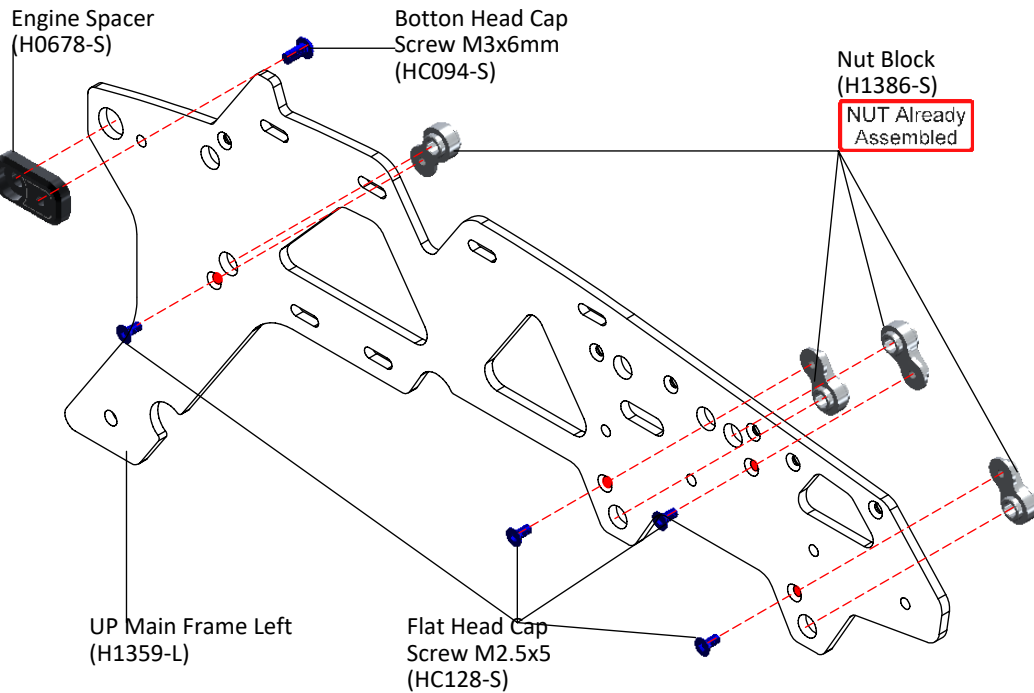

RIGHT UPPER MAIN FRAME ASSEMBLY

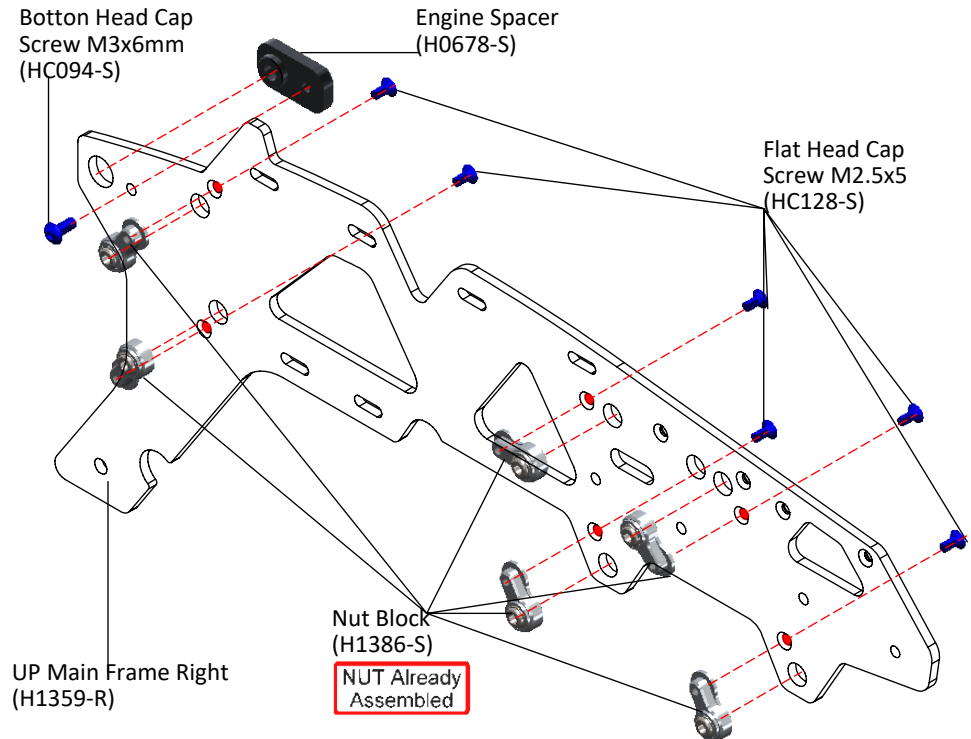

BOX 1, BAG FOR PAGE 9

NOTE: Do not tighten the 7 M3 screws at this stage, screw will be tightened on page 25 when adjusting the main belt tension.

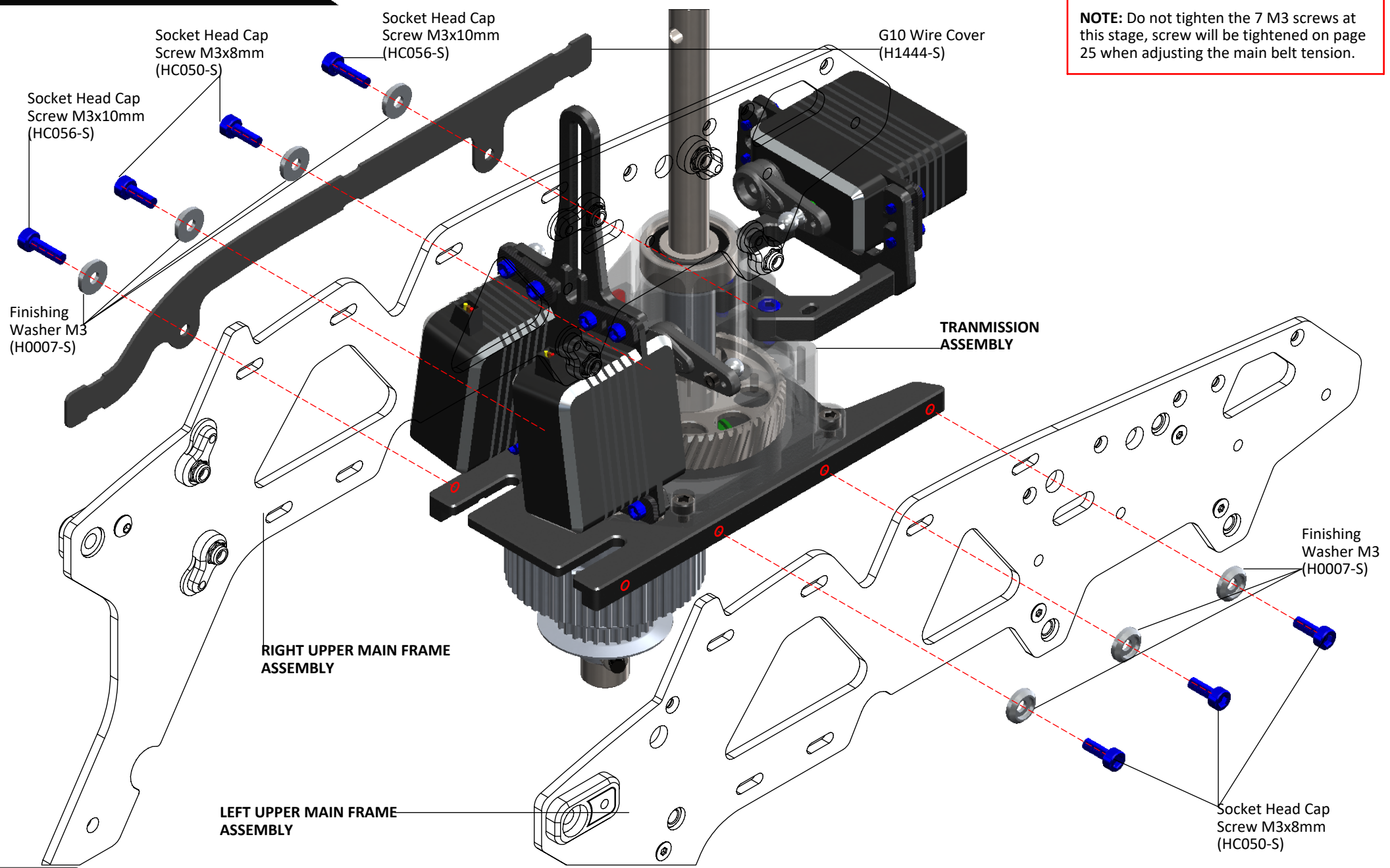

UNIBALL RADIUS ARM ASSEMBLY ...x2

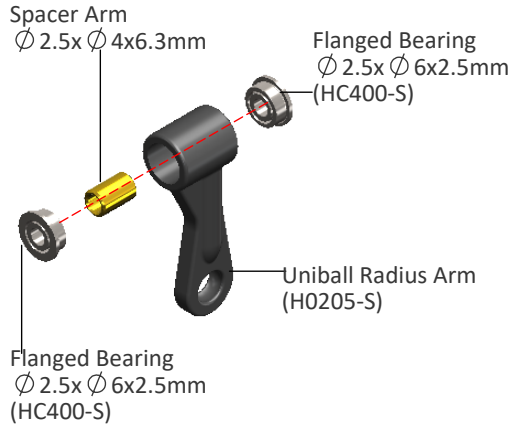

RADIUS ARM ASSEMBLY ...x2

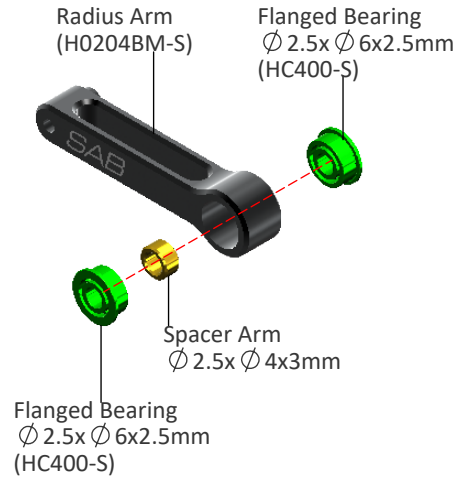

LINKAGE ROD ASSEMBLY ...x2

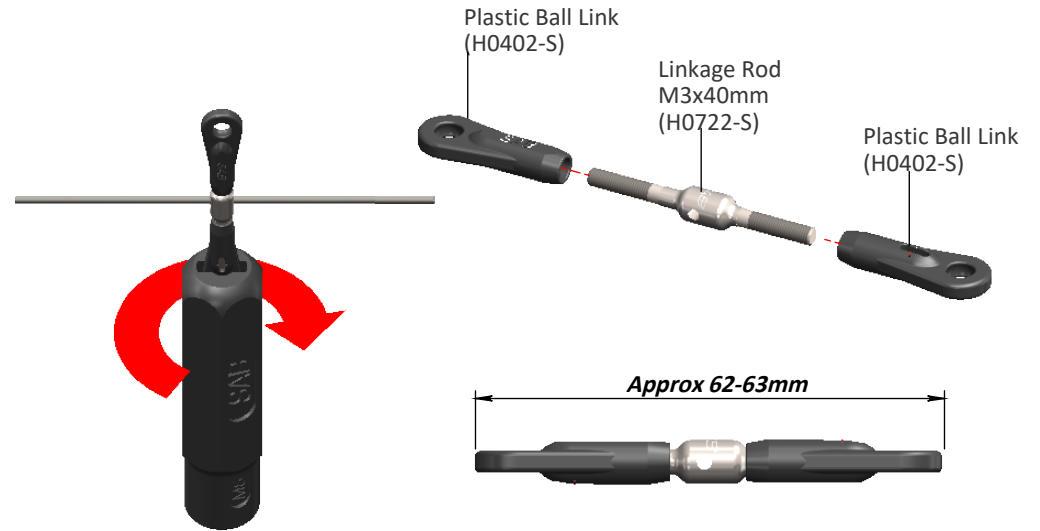

Note: You can use HA016 to assembly the plastic ball link.

CENTER HUB ASSEMBLY

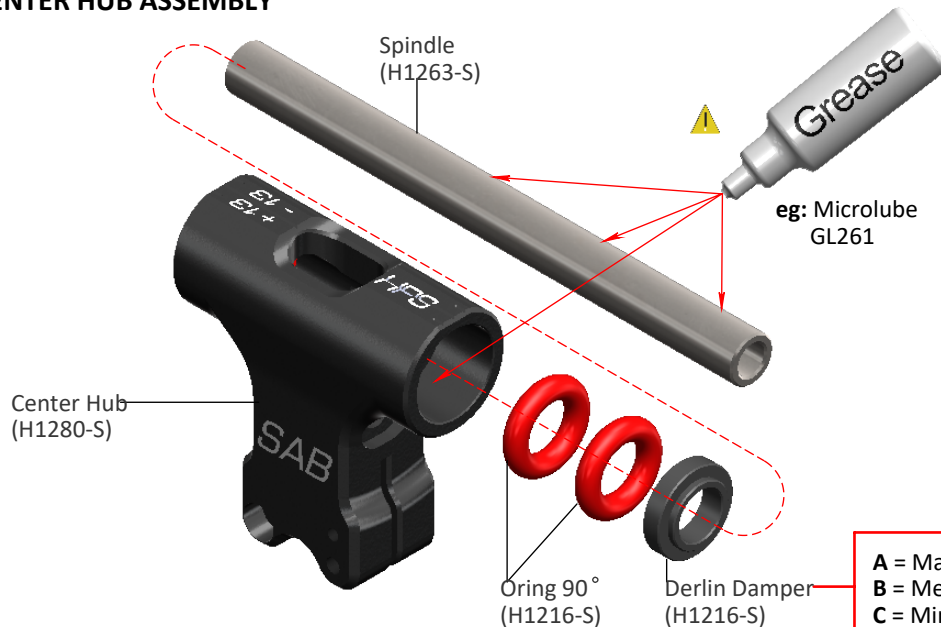

O-RING SET UP

Internal = 70°, External = 90° → Sport & 3D flight.

Internal = 90°, External = 90° → Hard 3D.

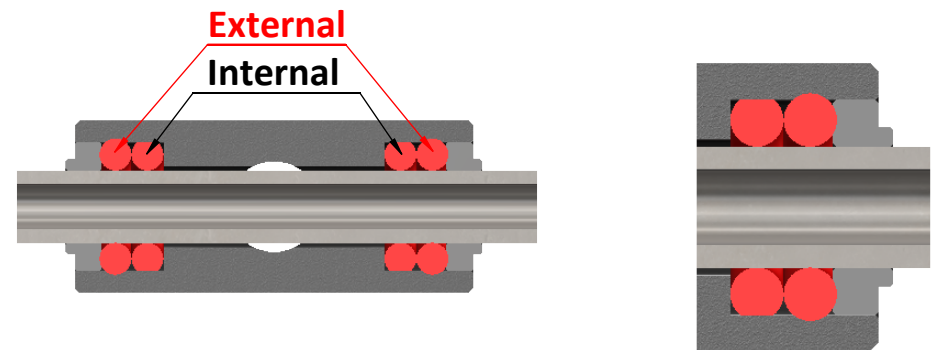

A = Max movement of the spindle, feeling more elastic. (**Sport**)
B = Medium. (**3D**)
C = Min movement of the spindle, feeling more direct. (**Hard 3D**)

NOTE: The small lip faces out towards the blade grip.

BOX 1, BAG FOR PAGE 11

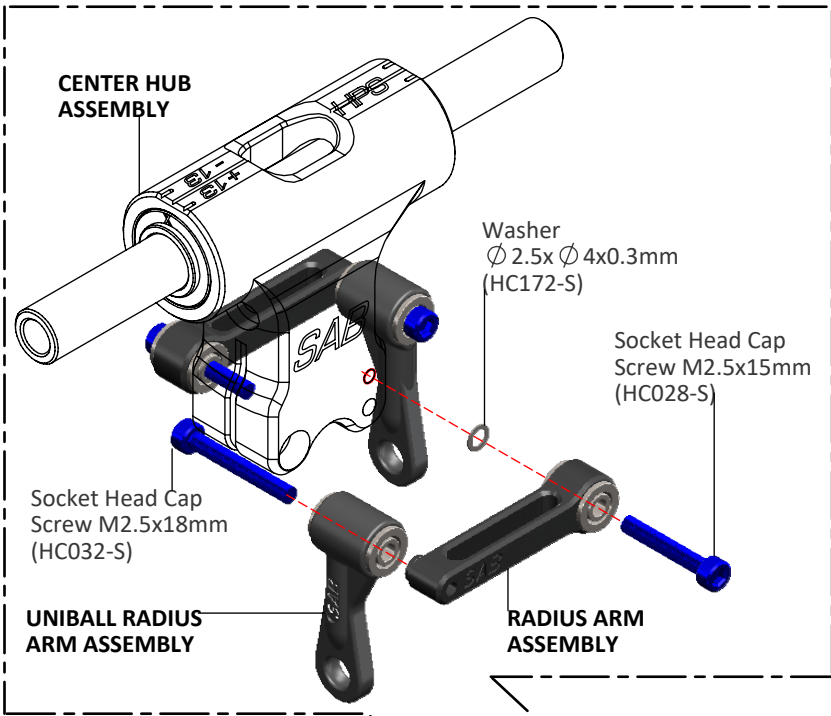

NOTE:
 Washer $\phi 8 \times \phi 14 \times 0.2\text{mm}$ [HC228-S]
 After approximately 10/20 flights, please check preload, you can add one 0.2mm shim on each side if preload has changed (Extra bag box 2). However, we suggest to replace the o-rings after about 100 flights.

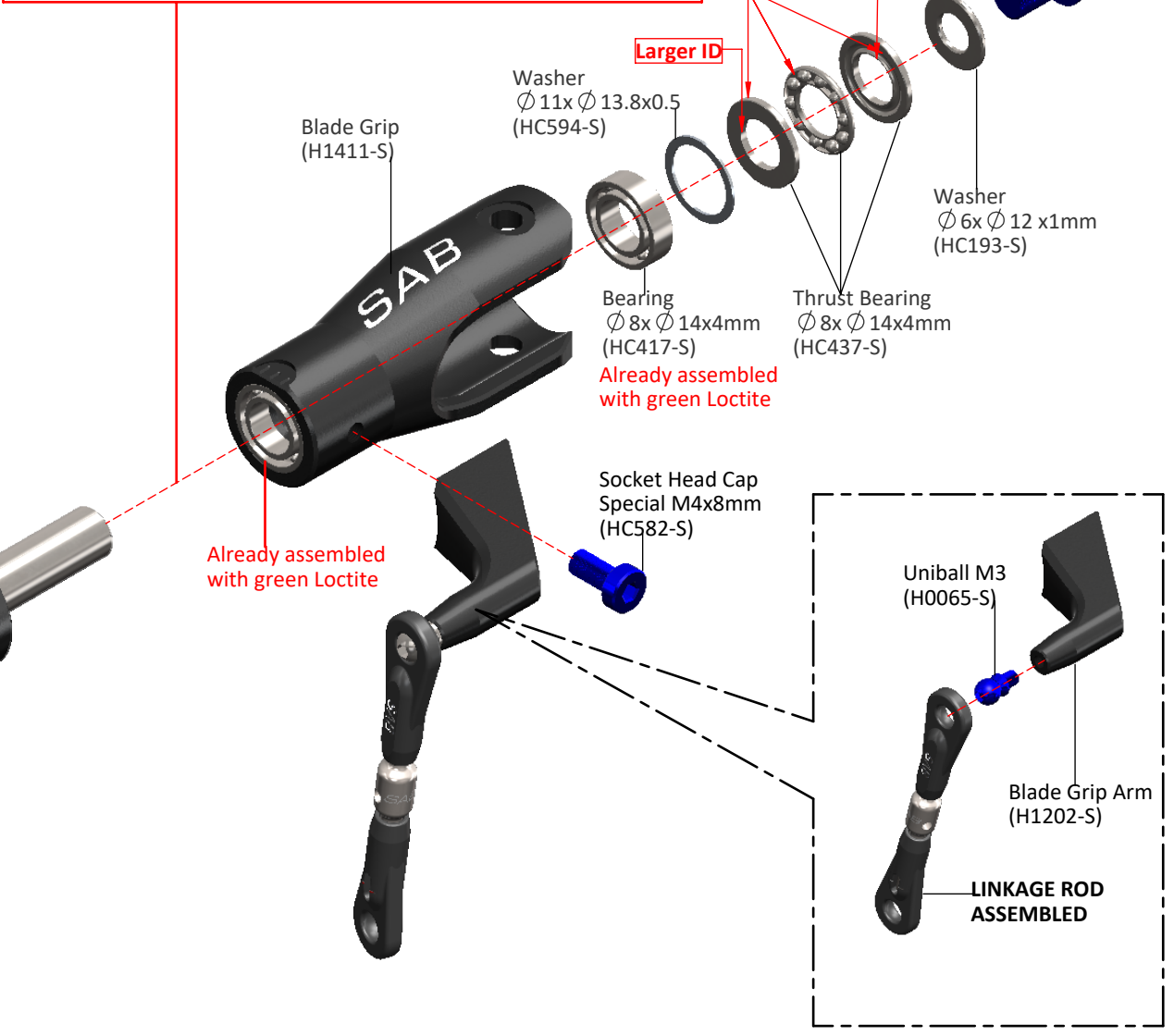

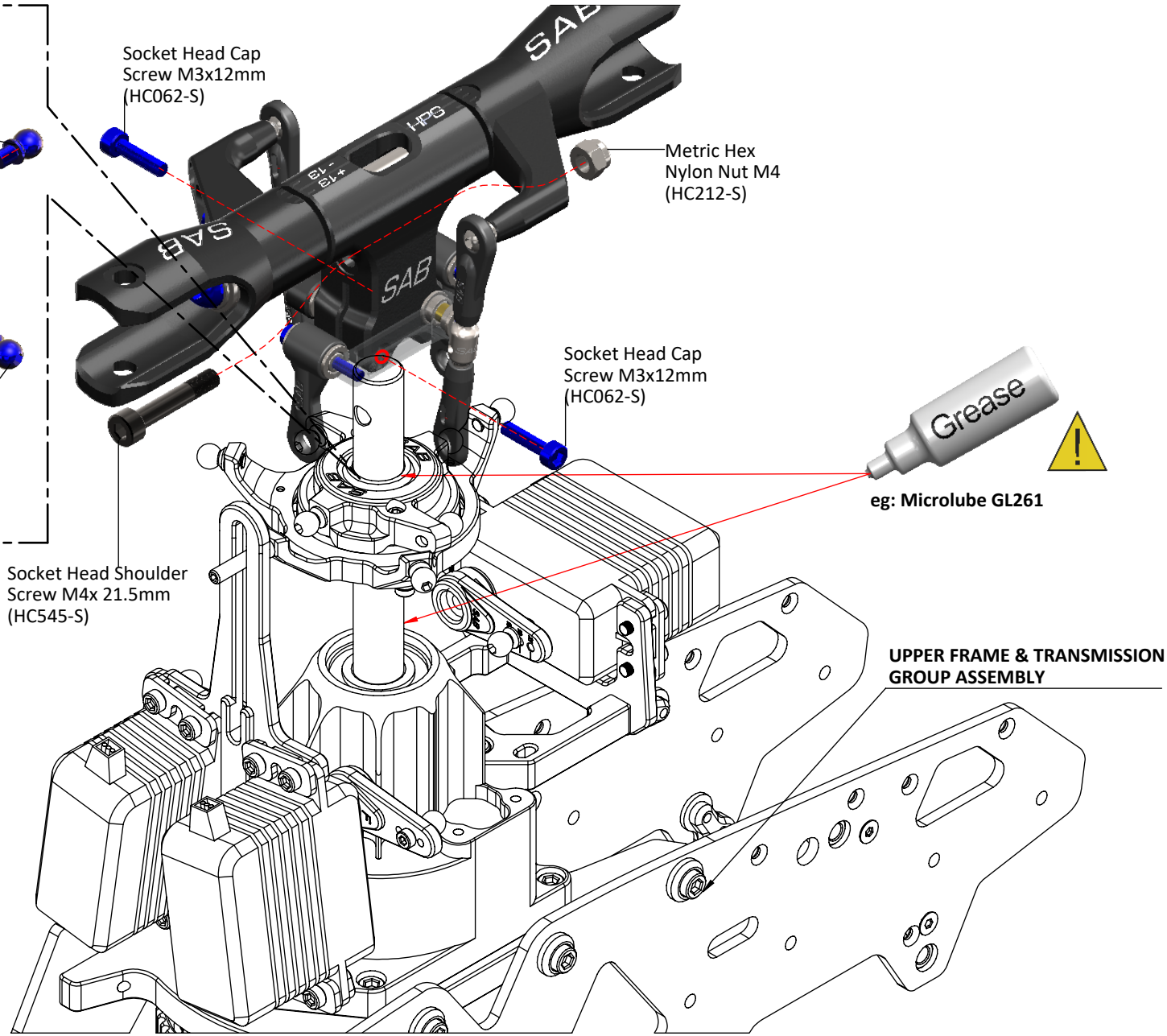
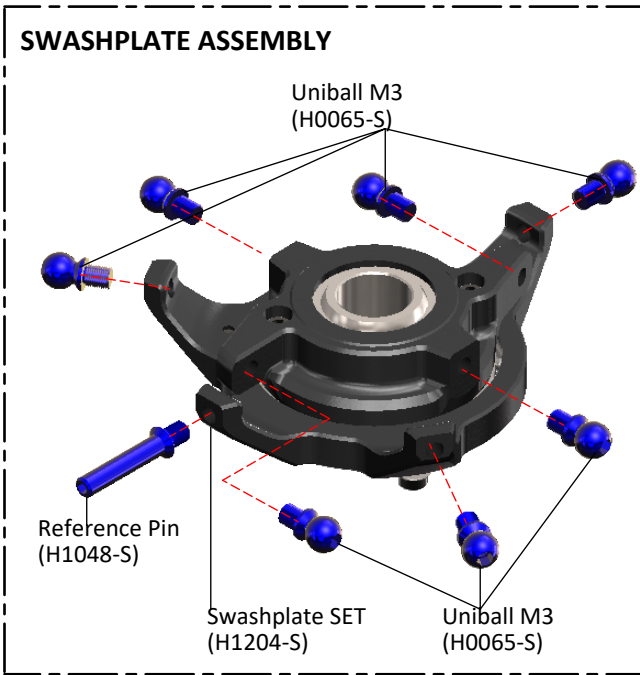

BOX 1, BAG FOR PAGE 13

LINKAGE ROD B ASSEMBLY ... X3
Approx 45mm

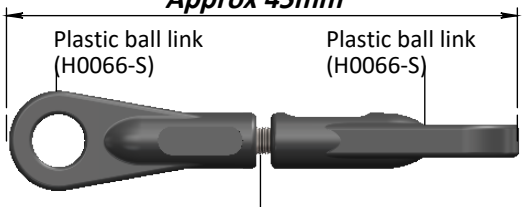

Plastic ball link (H0066-S) Plastic ball link (H0066-S)

Set Screw M2.5x18mm (HC140-S)

Initial length for the rods from the servos to the swash plate.

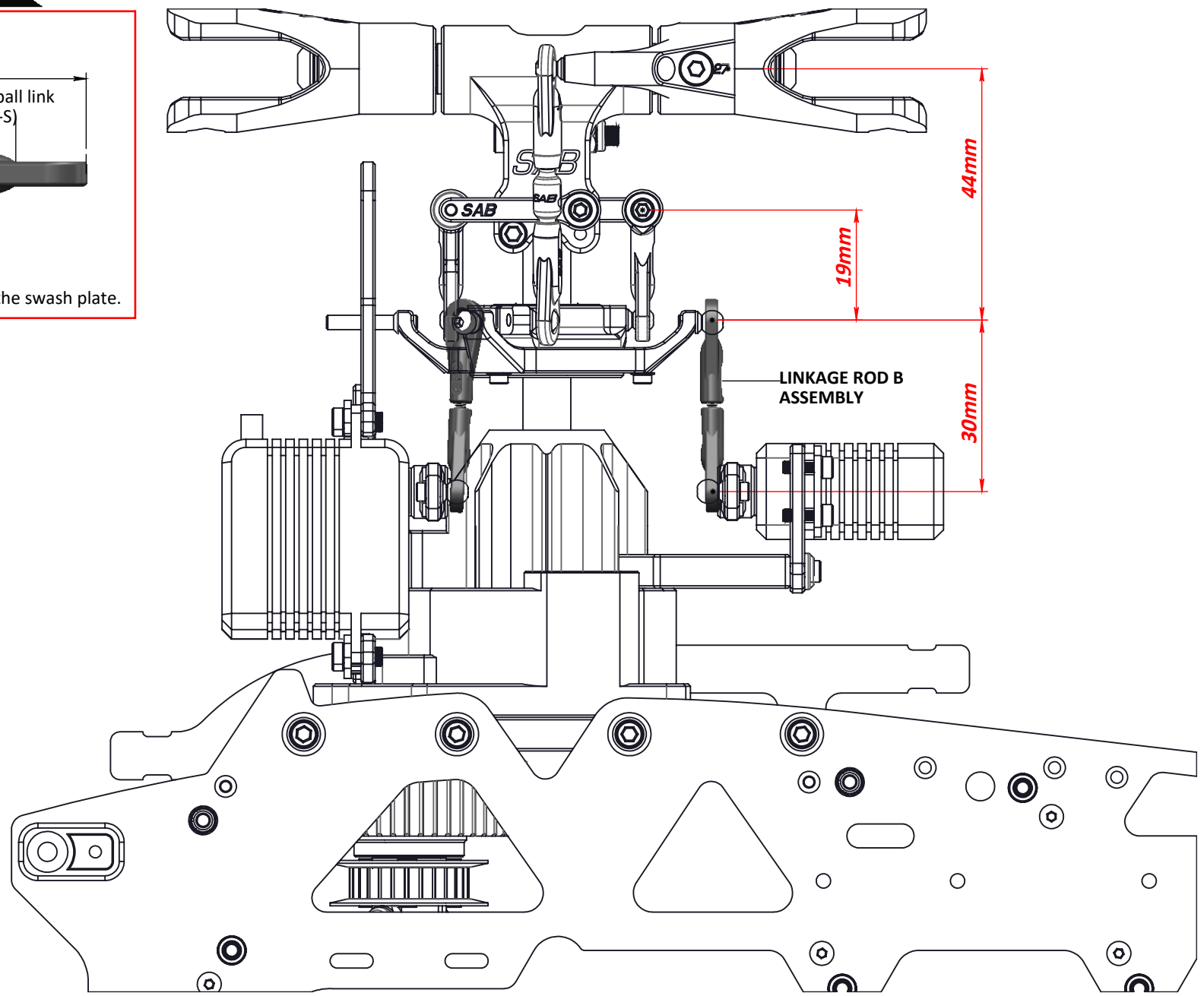

BOX 1, BAG FOR PAGE 14

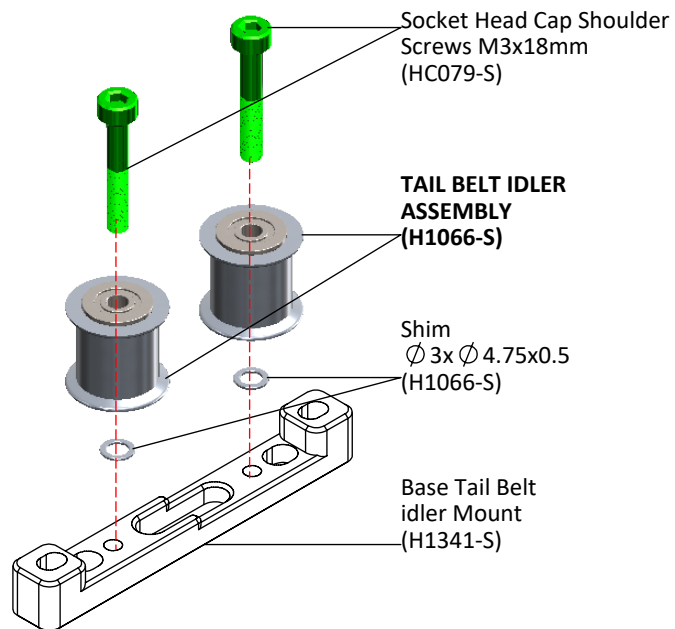

1

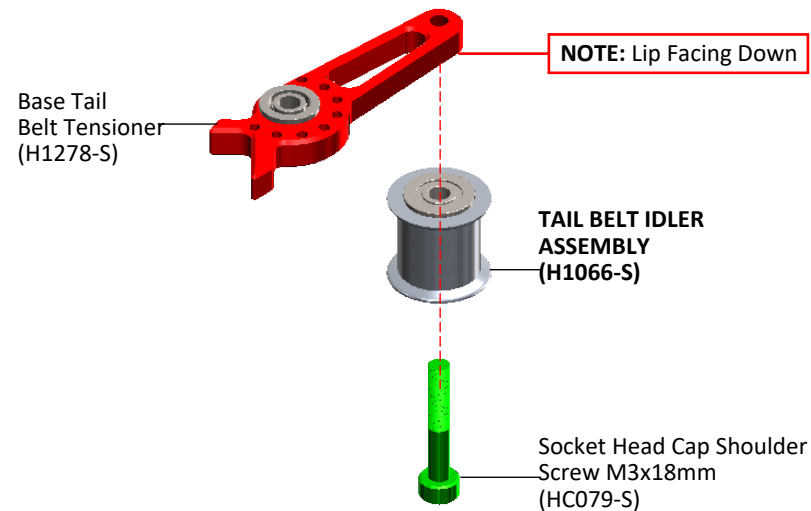

2

3

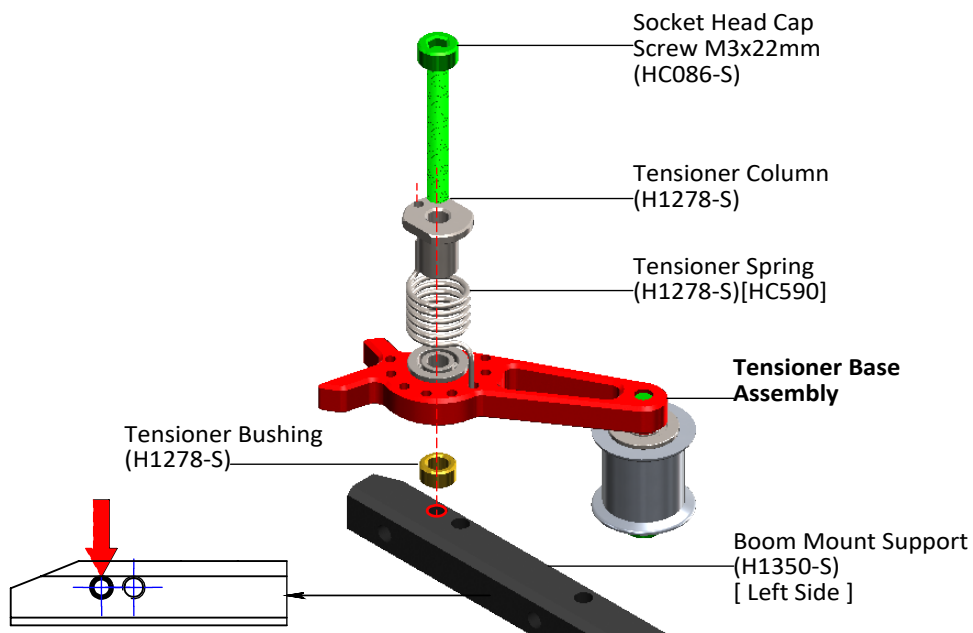

NOTE: Position without Spring pre-load.

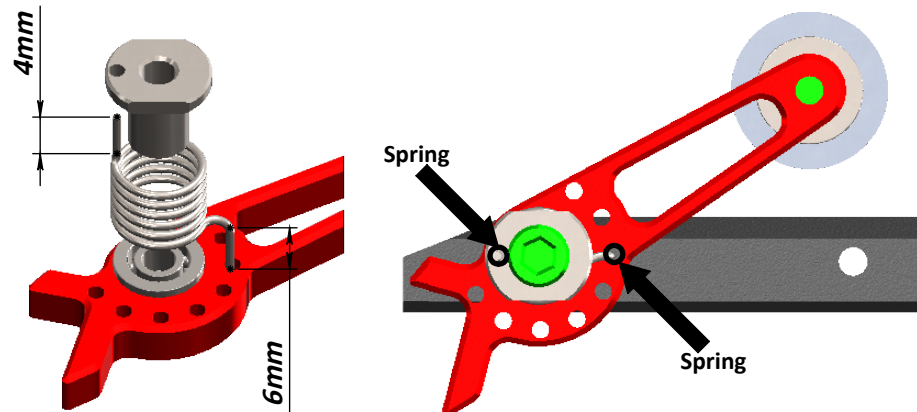

BOX 1, BAG FOR PAGE 15

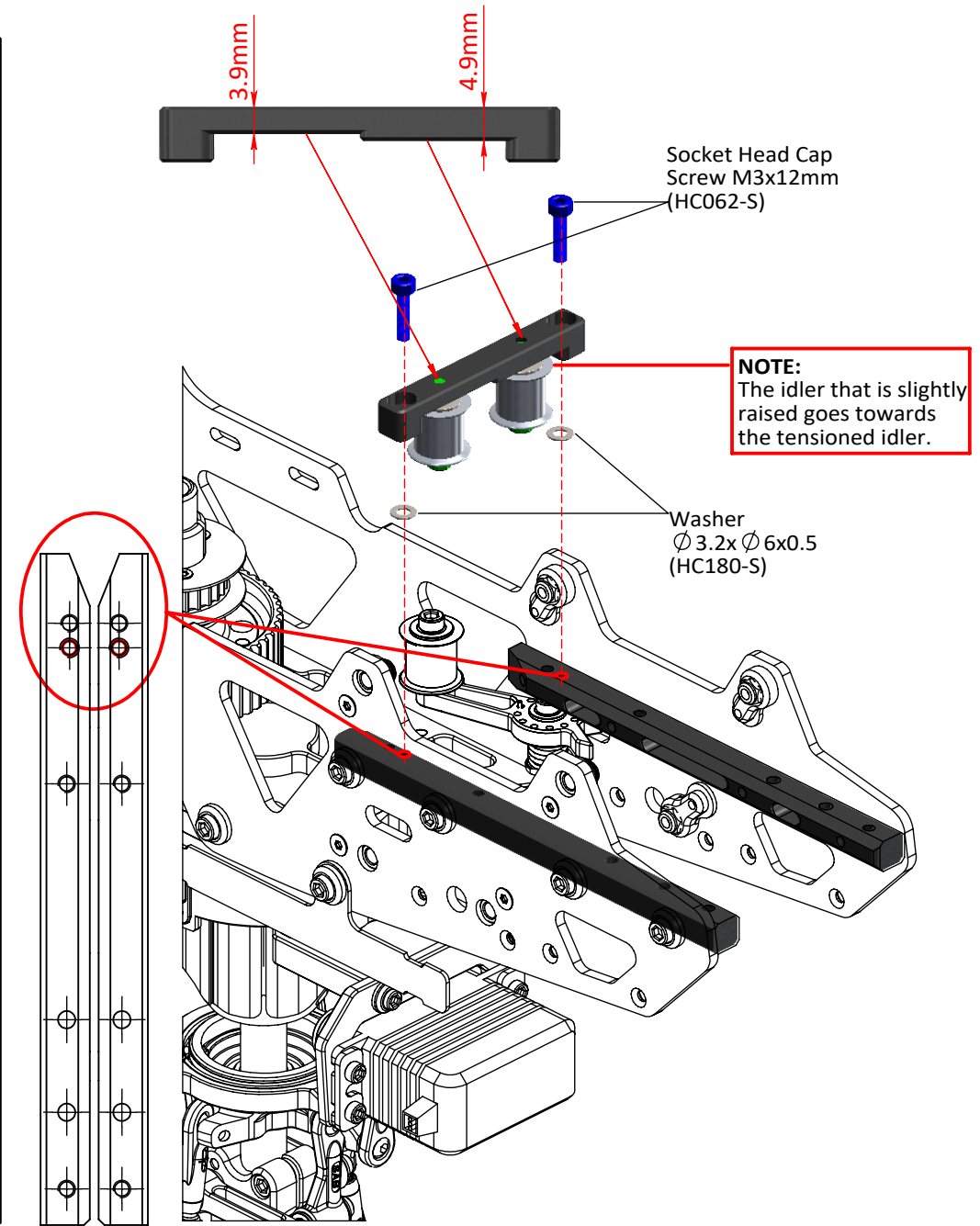
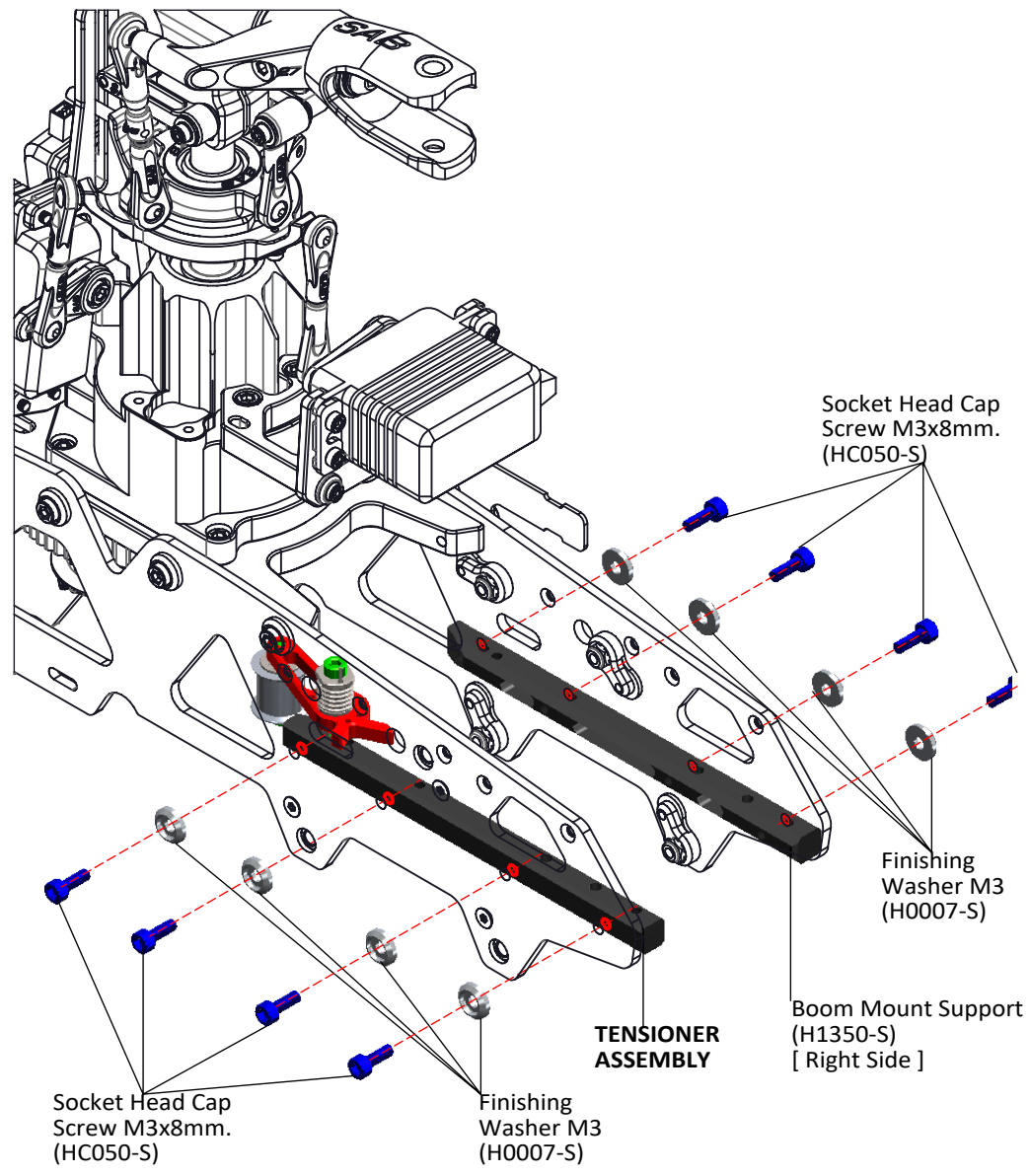

LOWER SIDE FRAME ASSEMBLY

BOX 3, BAG FOR PAGE 16

LOWER RIGHT MAIN FRAME ASSEMBLY

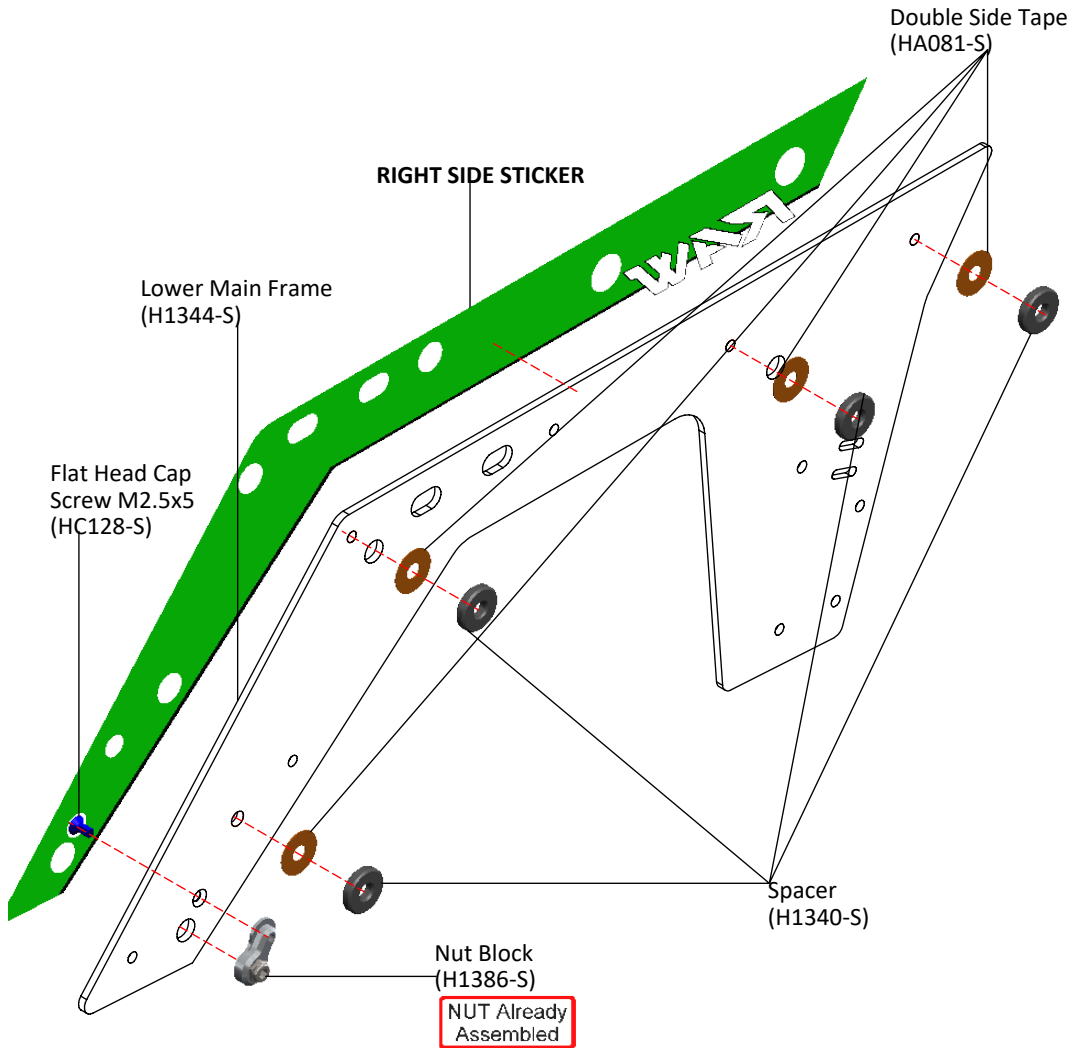

LOWER LEFT MAIN FRAME ASSEMBLY

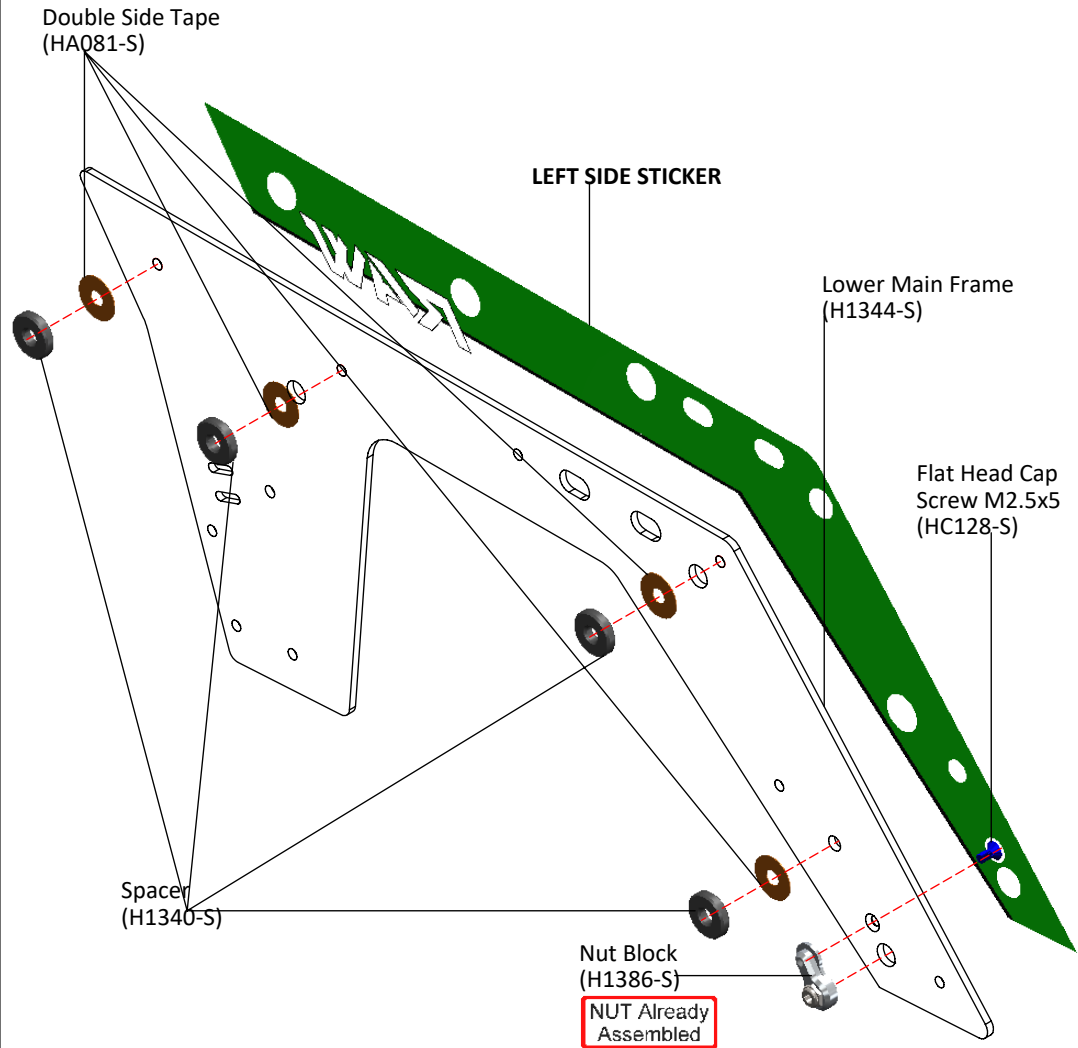

BOX 3, BAG FOR PAGE 17

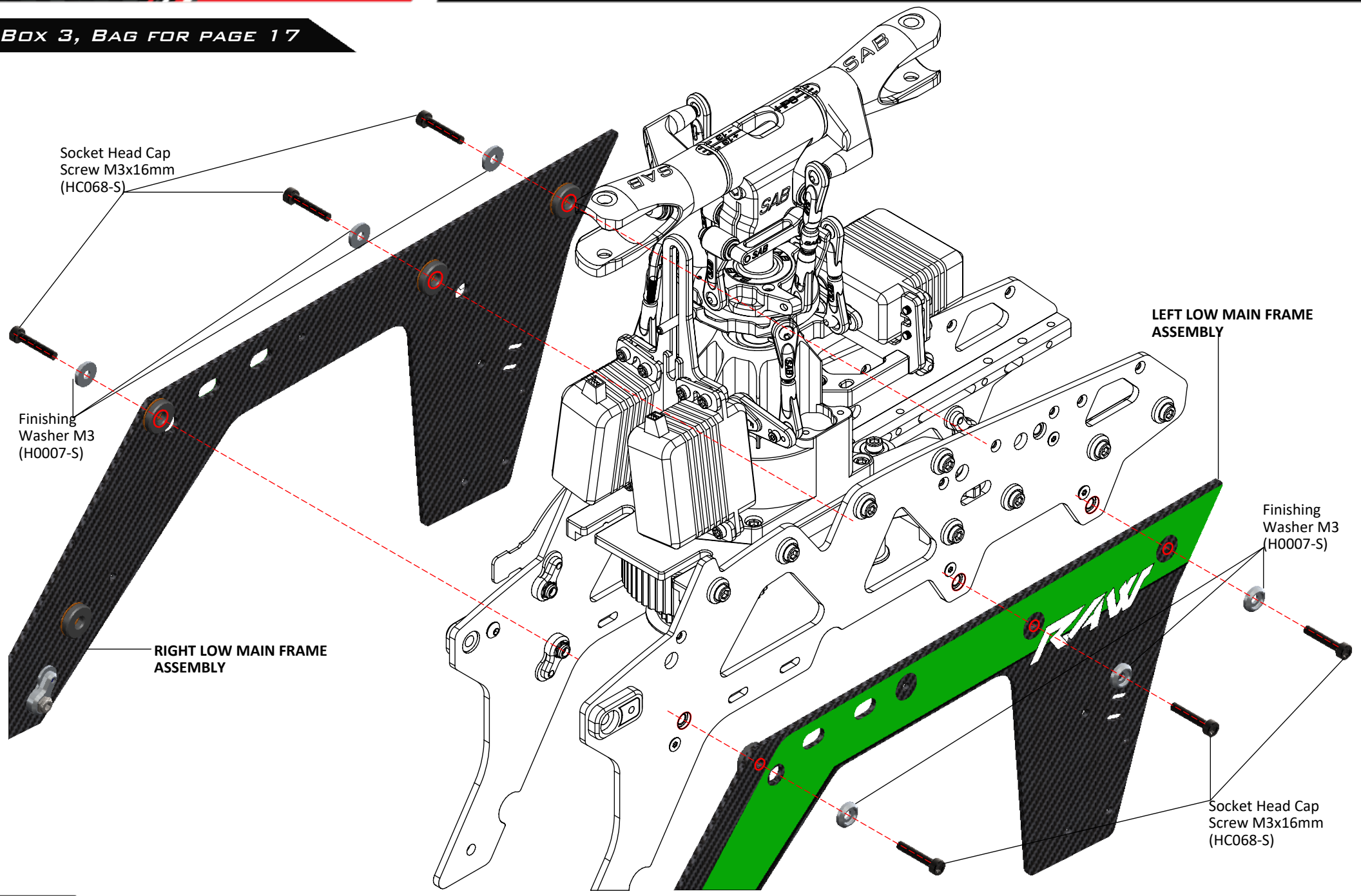

Socket Head Cap
Screw M3x16mm
(HC068-S)

Finishing
Washer M3
(H0007-S)

**RIGHT LOW MAIN FRAME
ASSEMBLY**

**LEFT LOW MAIN FRAME
ASSEMBLY**

Finishing
Washer M3
(H0007-S)

Socket Head Cap
Screw M3x16mm
(HC068-S)

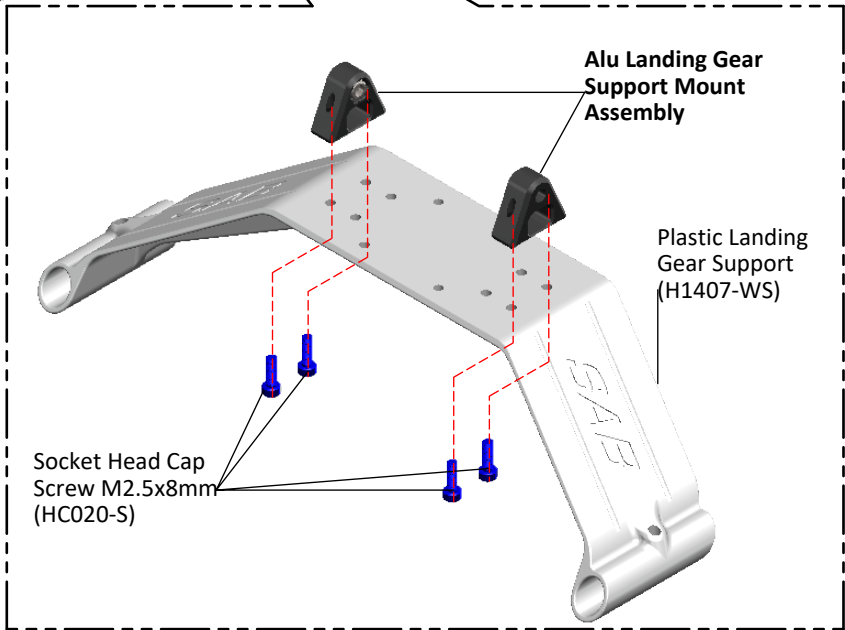
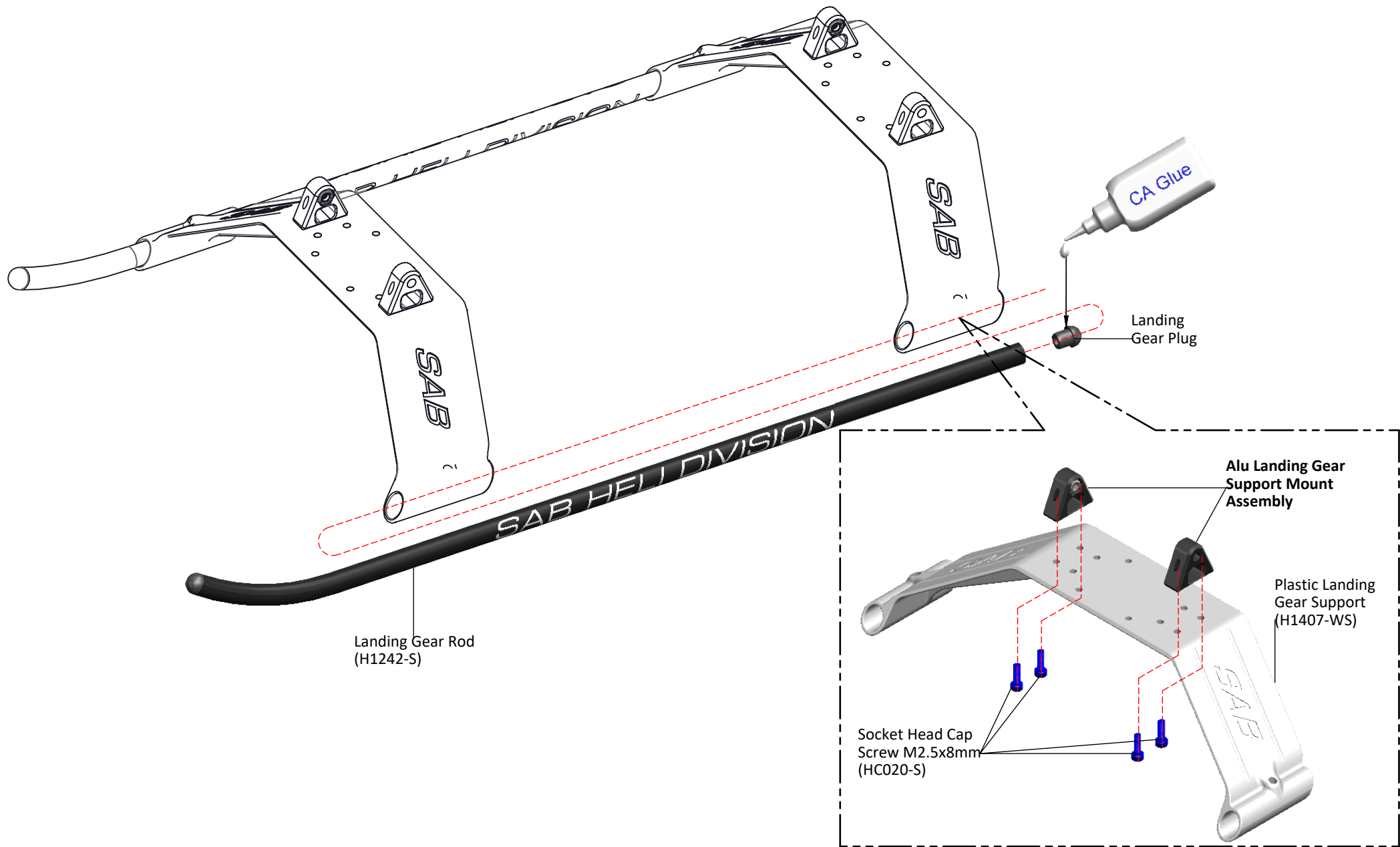

BOX 3, BAG FOR PAGE 19

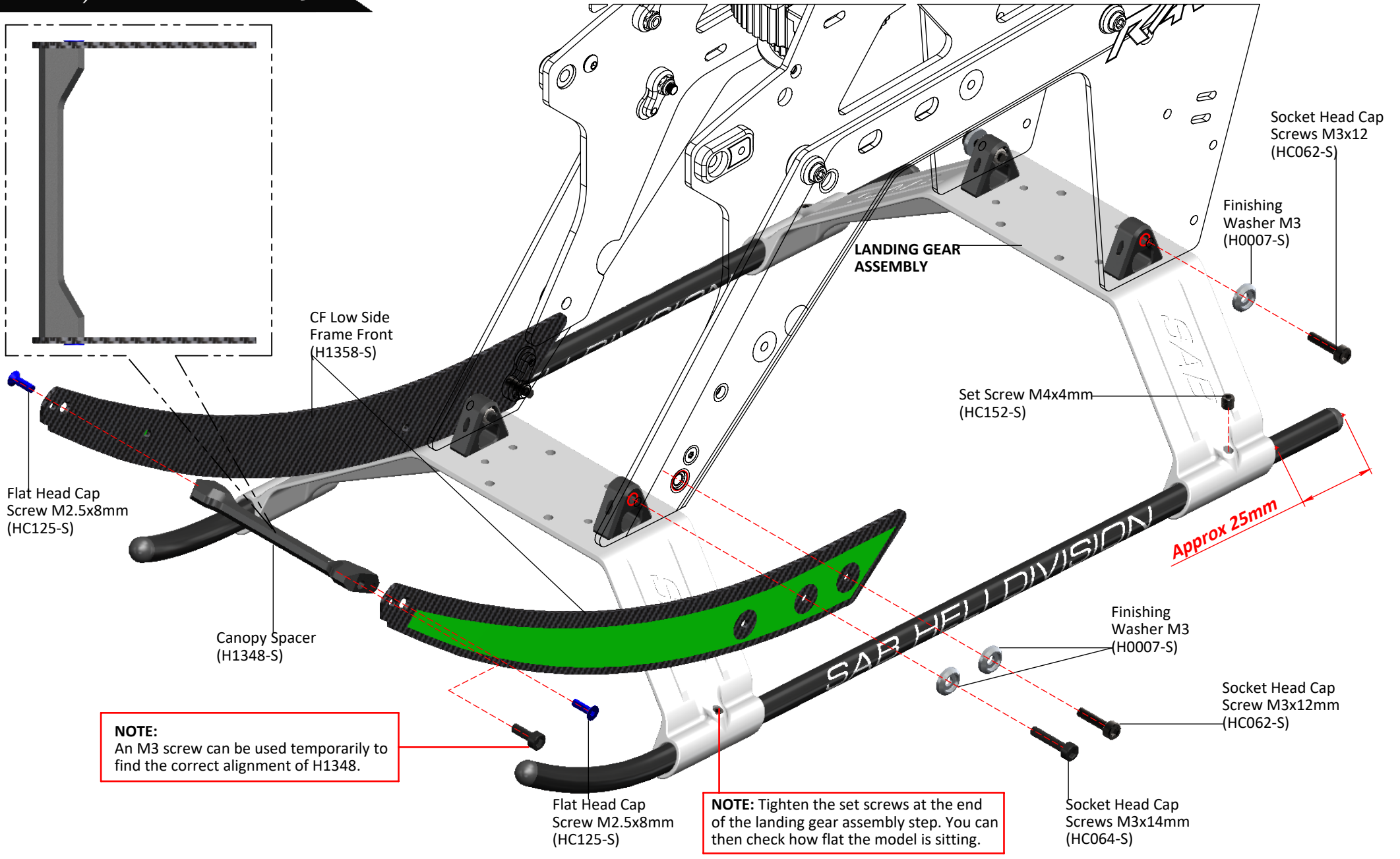

CLUTCH UNIT ASSEMBLY

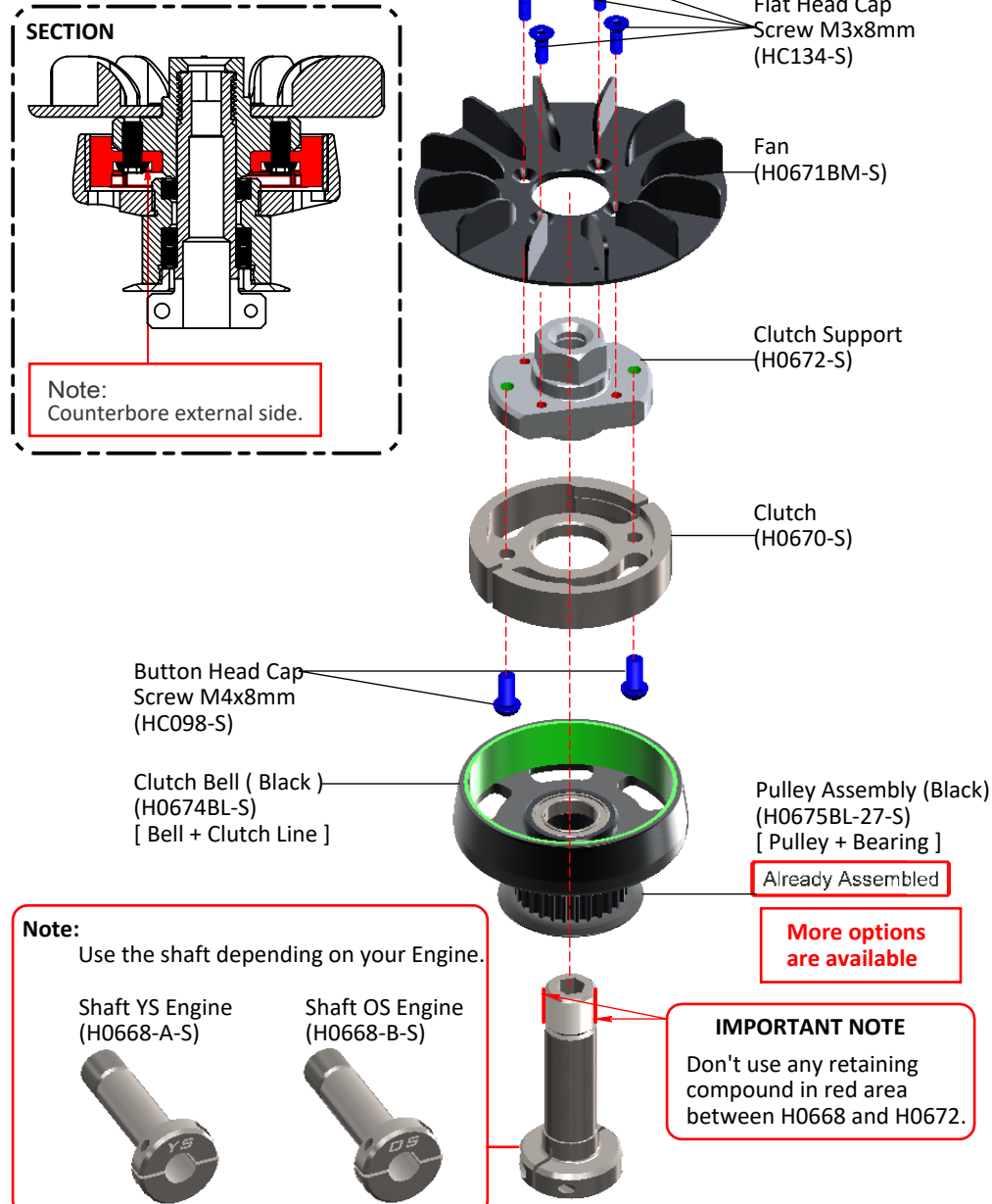

ENGINE MOUNT ASSEMBLY

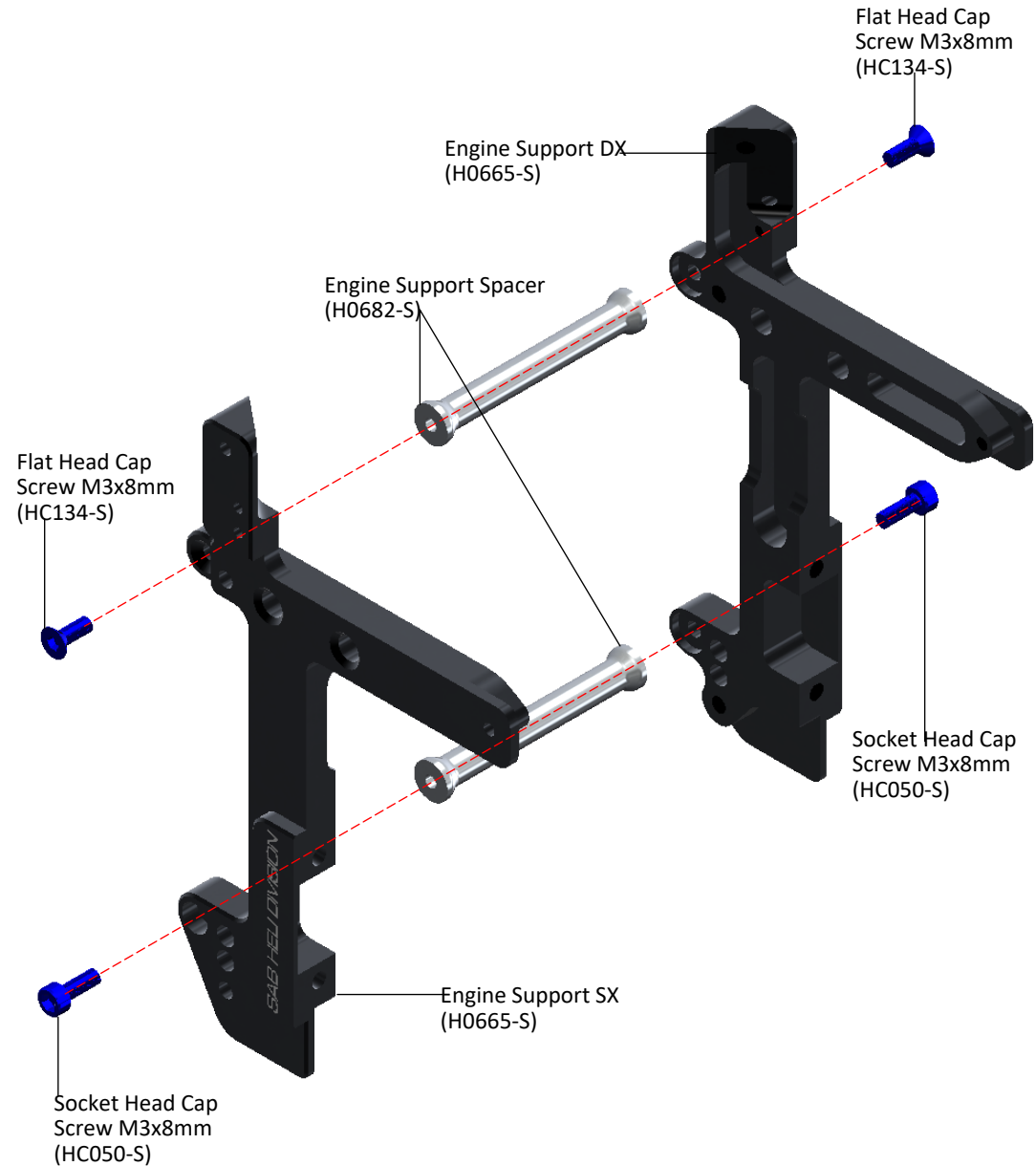

BOX 3, BAG FOR PAGE 21

ENGINE ASSEMBLY

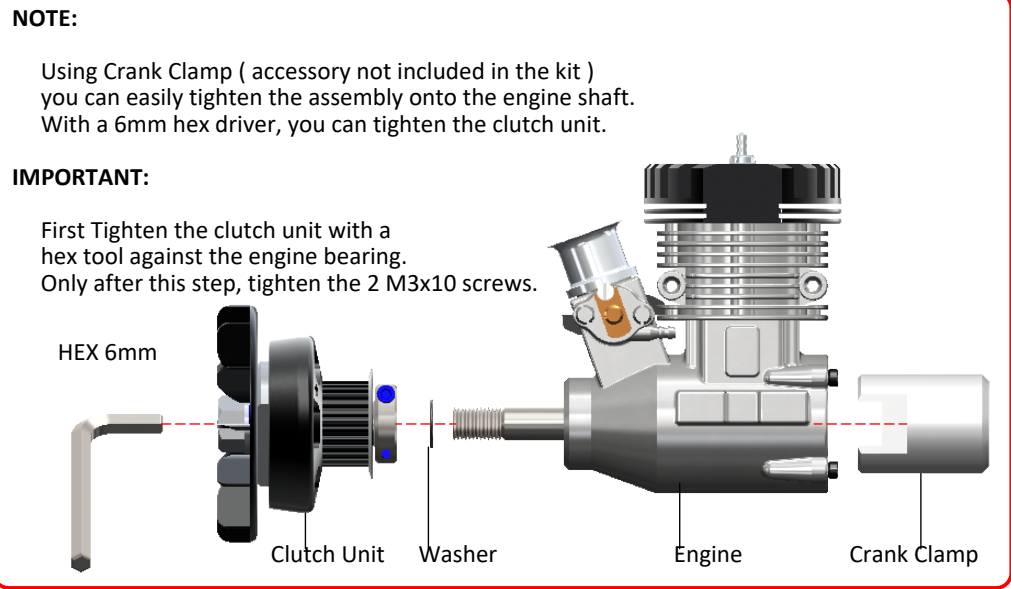
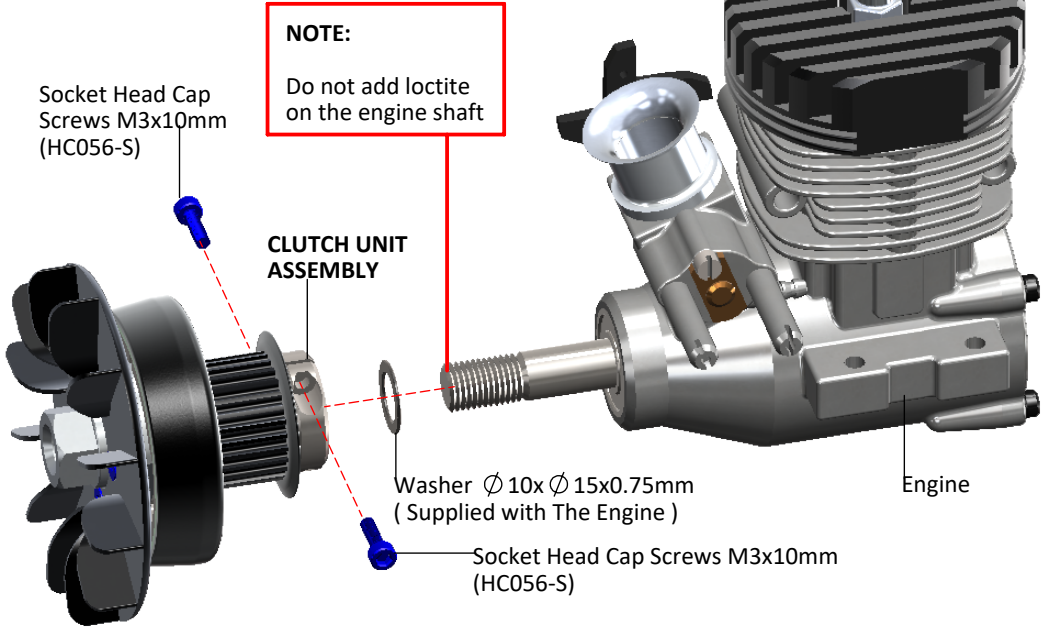

MAIN RATIO

It is possible to have 5 ratios using the following Pulleys:

H0675BL-28-S	52/28	7.7
H0675BL-27-S	52/27	8.0
H0675BL-26-S	52/26	8.3

The KIT includes ratio : 52T-27T -> 8.0

ENGINE MOUNT ASSEMBLY

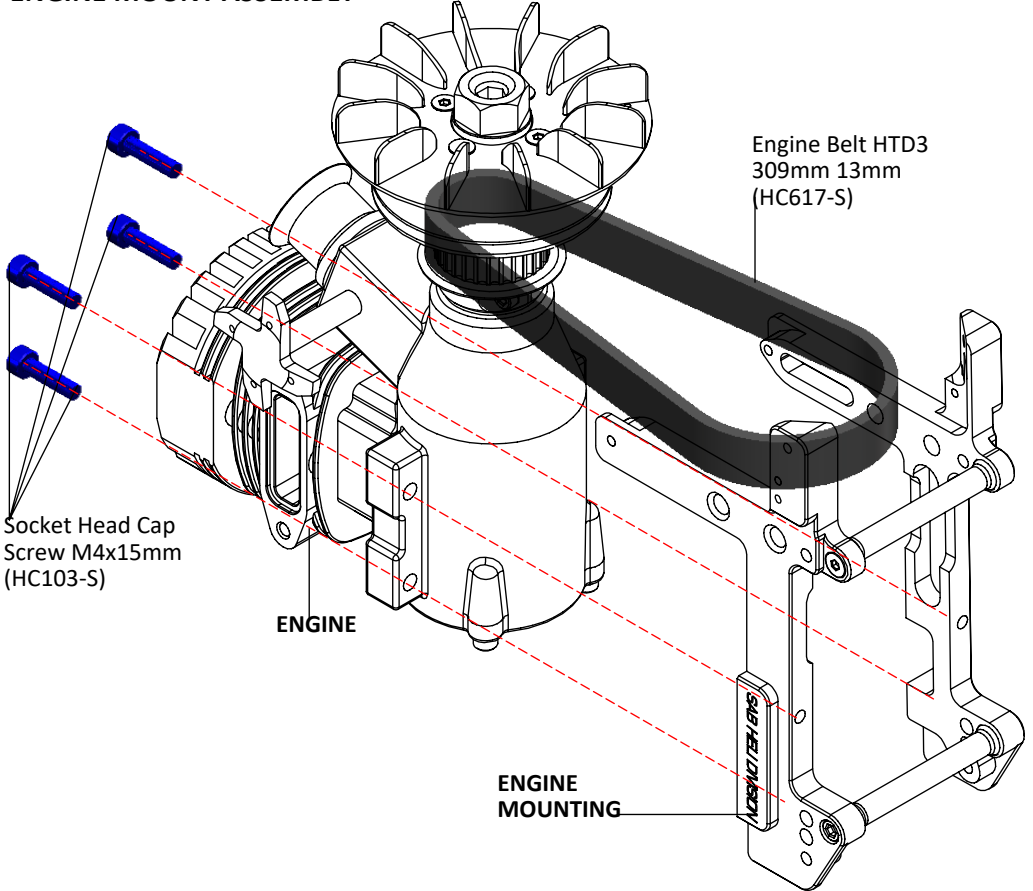

INSTALLATION OF THE RPM SENSOR

On the RAW nitro it is possible to use two different methods to install an RPM sensor. The first is a backplate sensor as demonstrated in the picture on the right.

P.S: Not all YS engines can support this method. Please seek further guidance from your engine manufacturer.

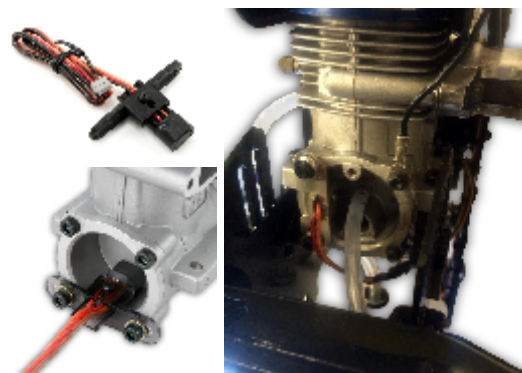

The second is to use two magnets on the fan. Please use the following methods for installation:

Install 2 magnets on the fan with epoxy glue (please ensure to clean the parts with degreaser before glueing together)

[Fig. 1]). To install the sensor, you can use the two pre-cut M2.5 holes.

Not all sensors are the same, so you can adapt the position with the carbon support (H0729).

With Align and Spartan sensors, you can use the part of the support that already has holes in it.

With any other sensor, you can use the part without holes and adapt as required.

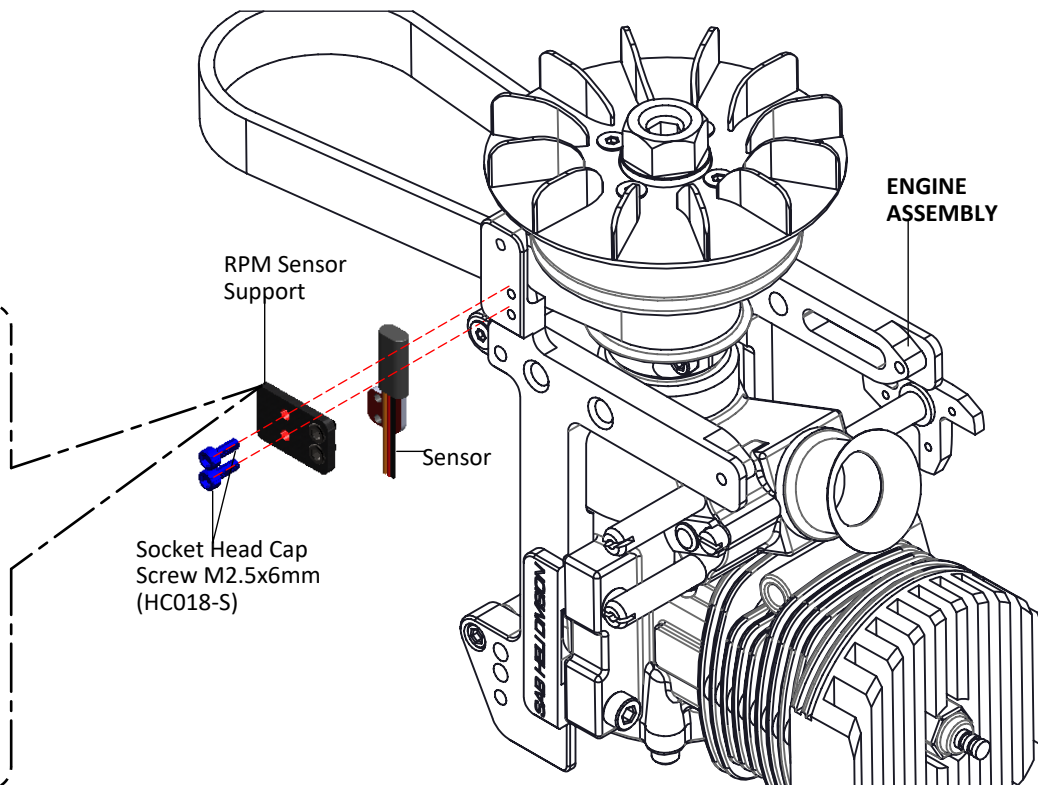
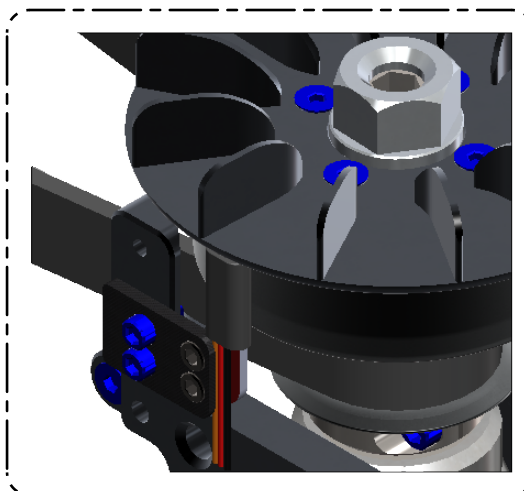
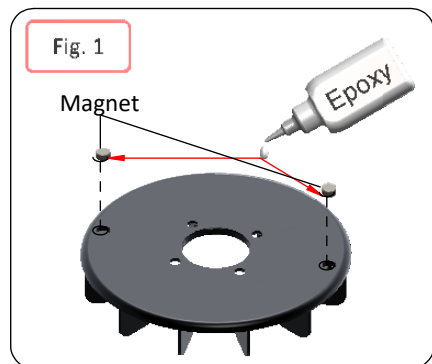
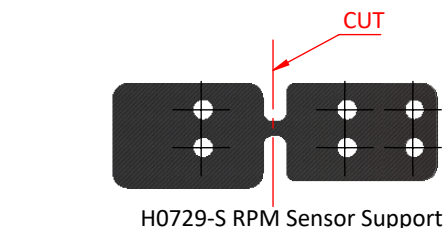

BOX 3, BAG FOR PAGE 23

FAN CASE SX ASSEMBLY

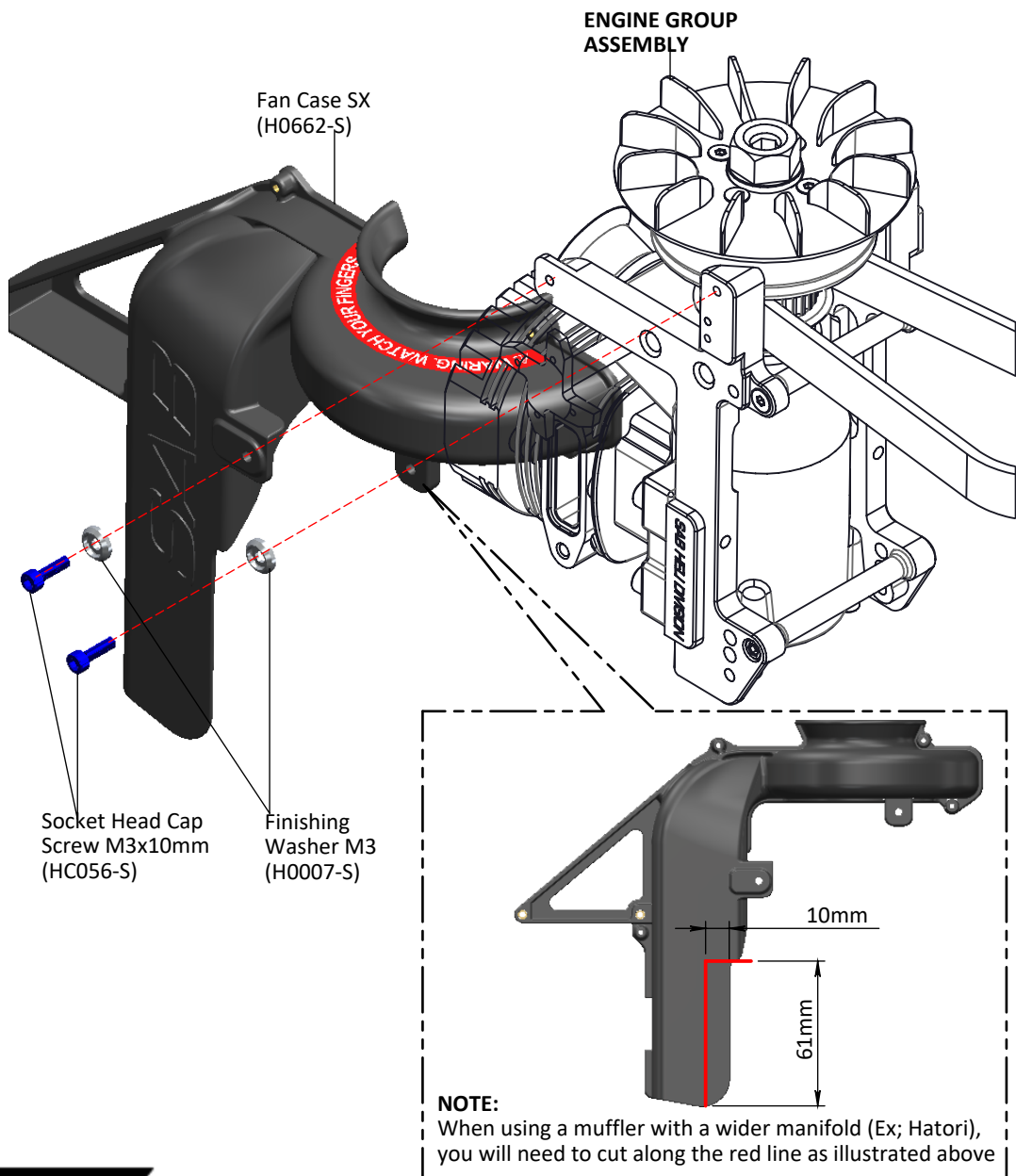

FAN CASE DX ASSEMBLY

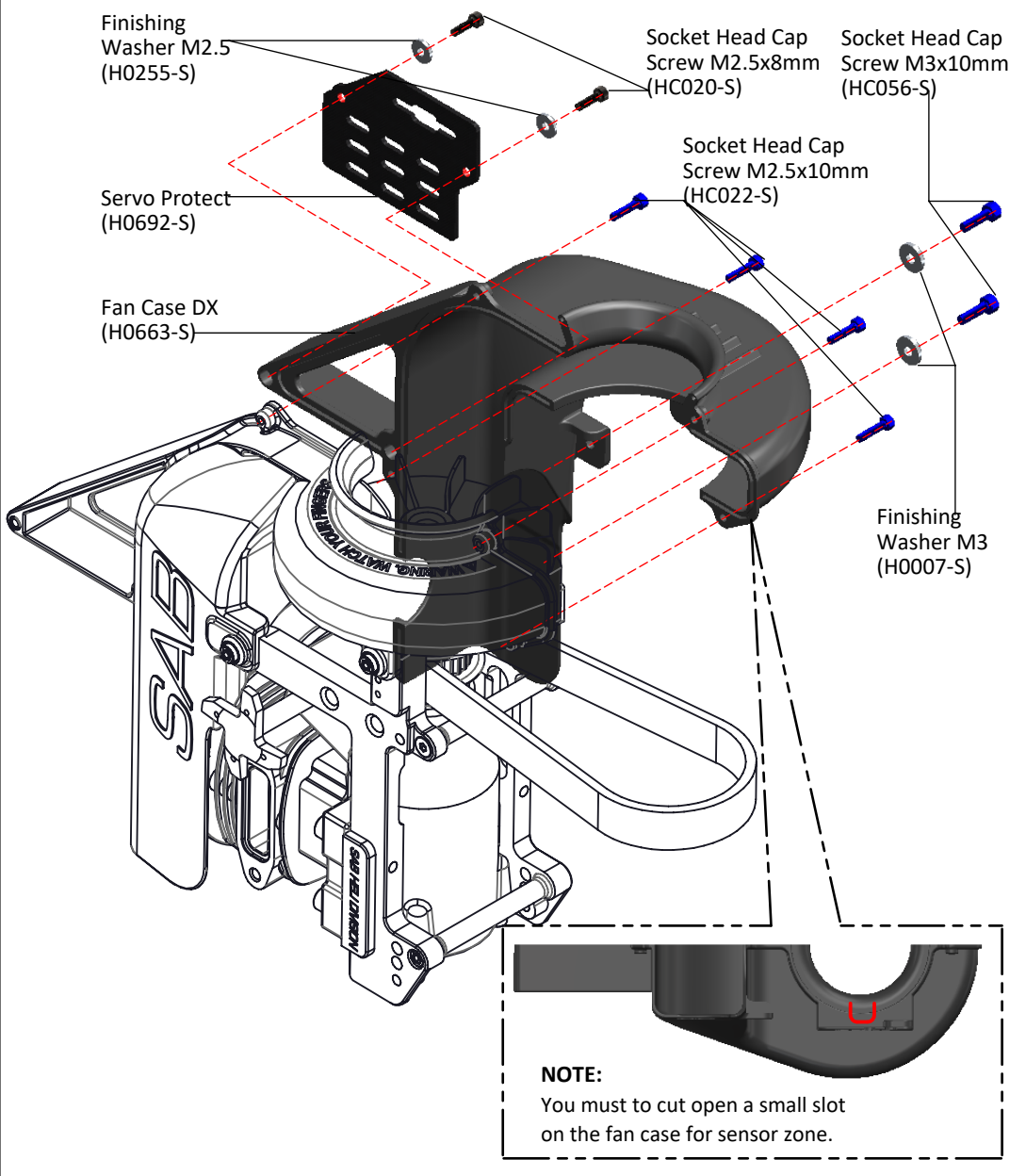

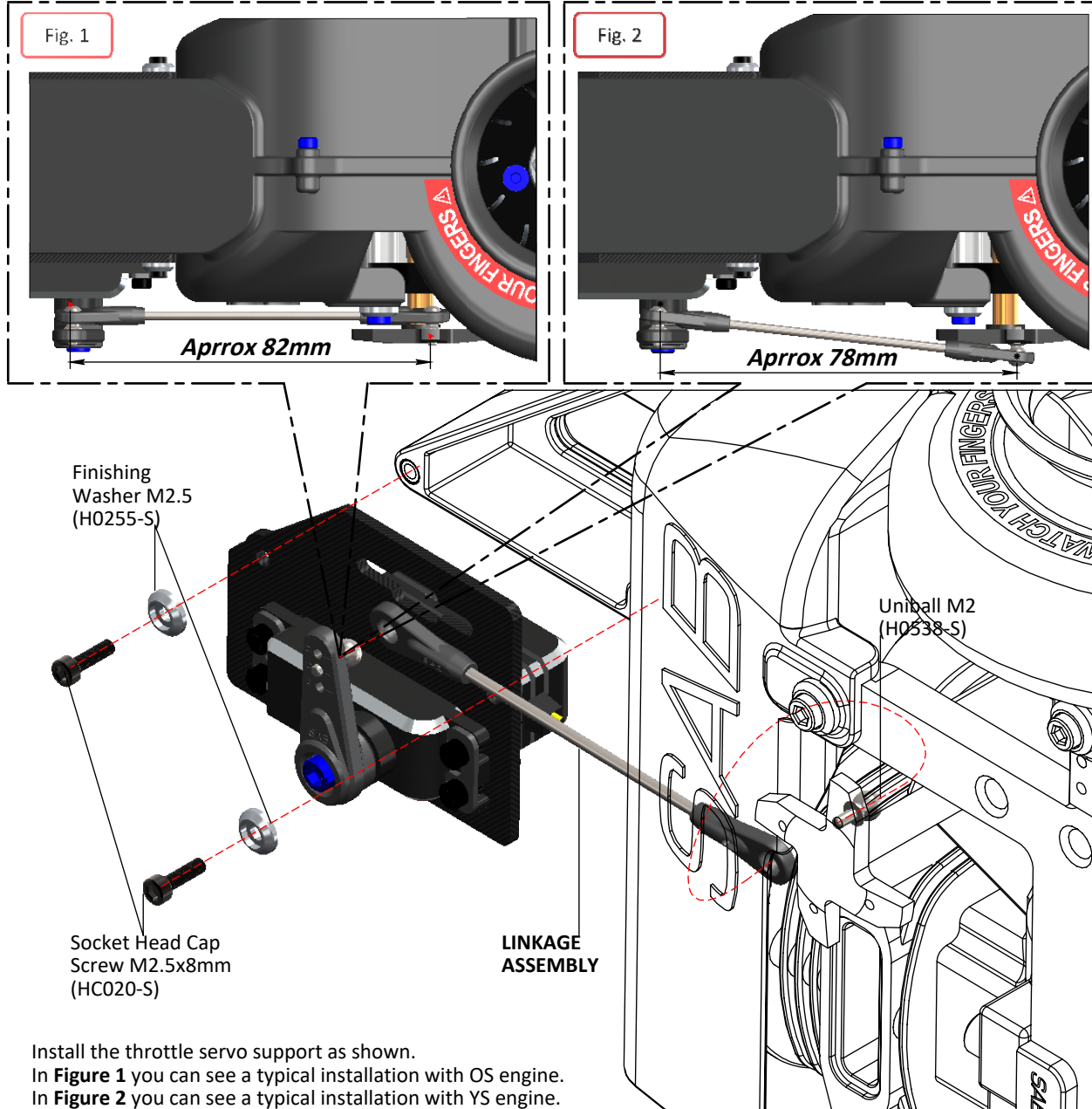

Install the throttle servo support as shown.
 In **Figure 1** you can see a typical installation with OS engine.
 In **Figure 2** you can see a typical installation with YS engine.

INSTALLATION OF THE THROTTLE SERVO

When installing the throttle servo, it is important to have the correct distance for the ball.

Approx 10-12mm

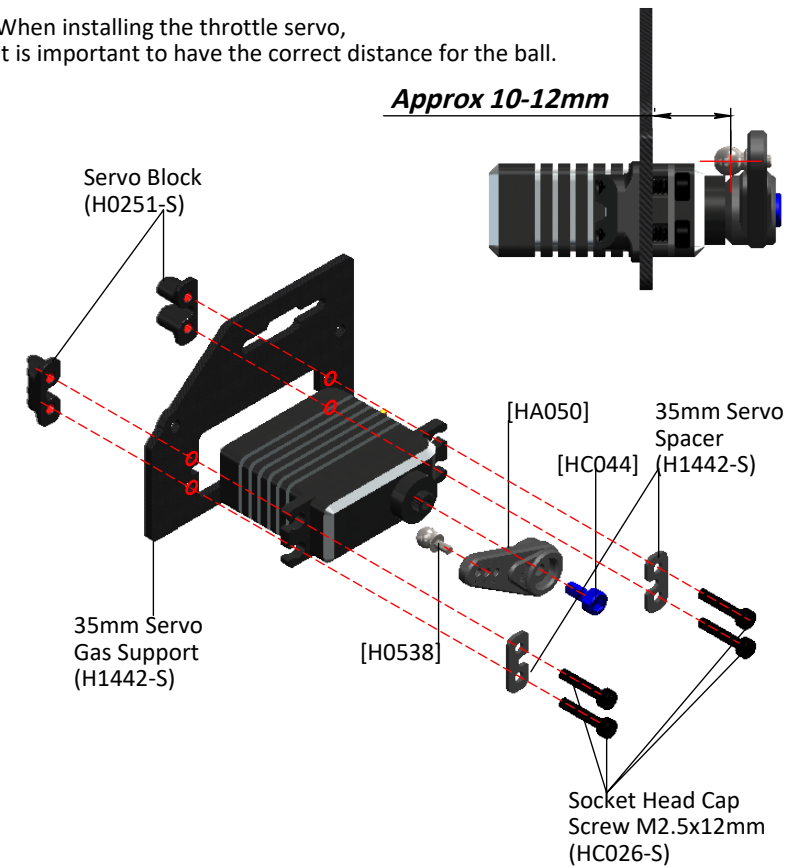

LINKAGE ASSEMBLY

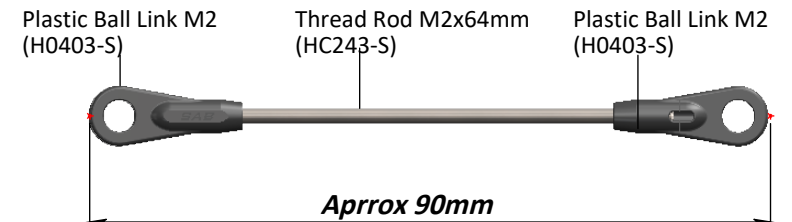

BOX 3, BAG FOR PAGE 25

NOTE:
Loosen all of the M3x8mm screws. Using a 5/6mm shaft, you can tension the engine belt.

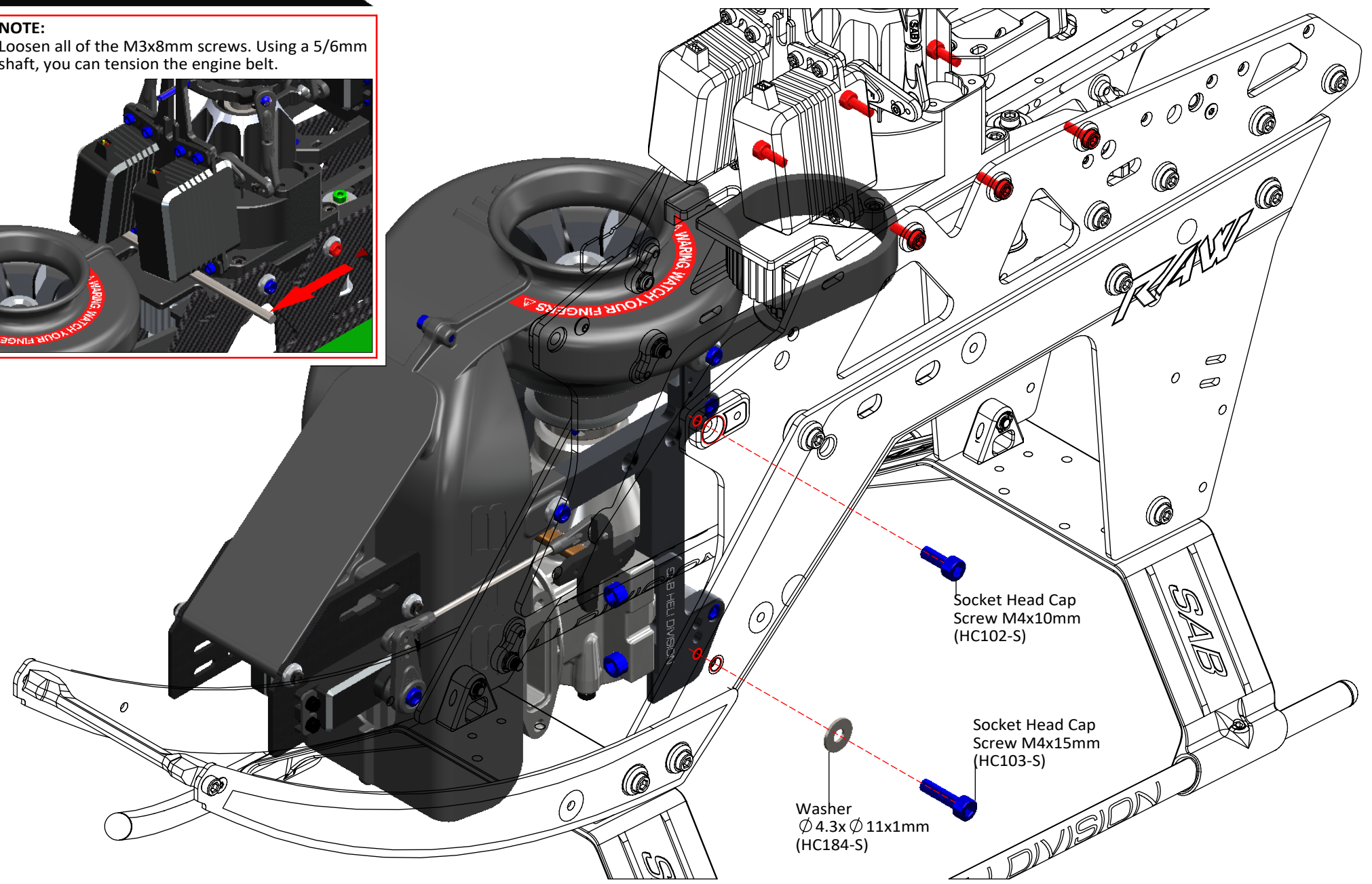

Socket Head Cap Screw M4x10mm (HC102-S)

Socket Head Cap Screw M4x15mm (HC103-S)

Washer $\varnothing 4.3 \times \varnothing 11 \times 1$ mm (HC184-S)

NOTE:

It is normal for the tail to feel a bit tight after initial assembly as the tail spindle preload is usually high when the helicopter is brand new. The preload will loosen up after 2-5 flights allowing the system to become smooth.

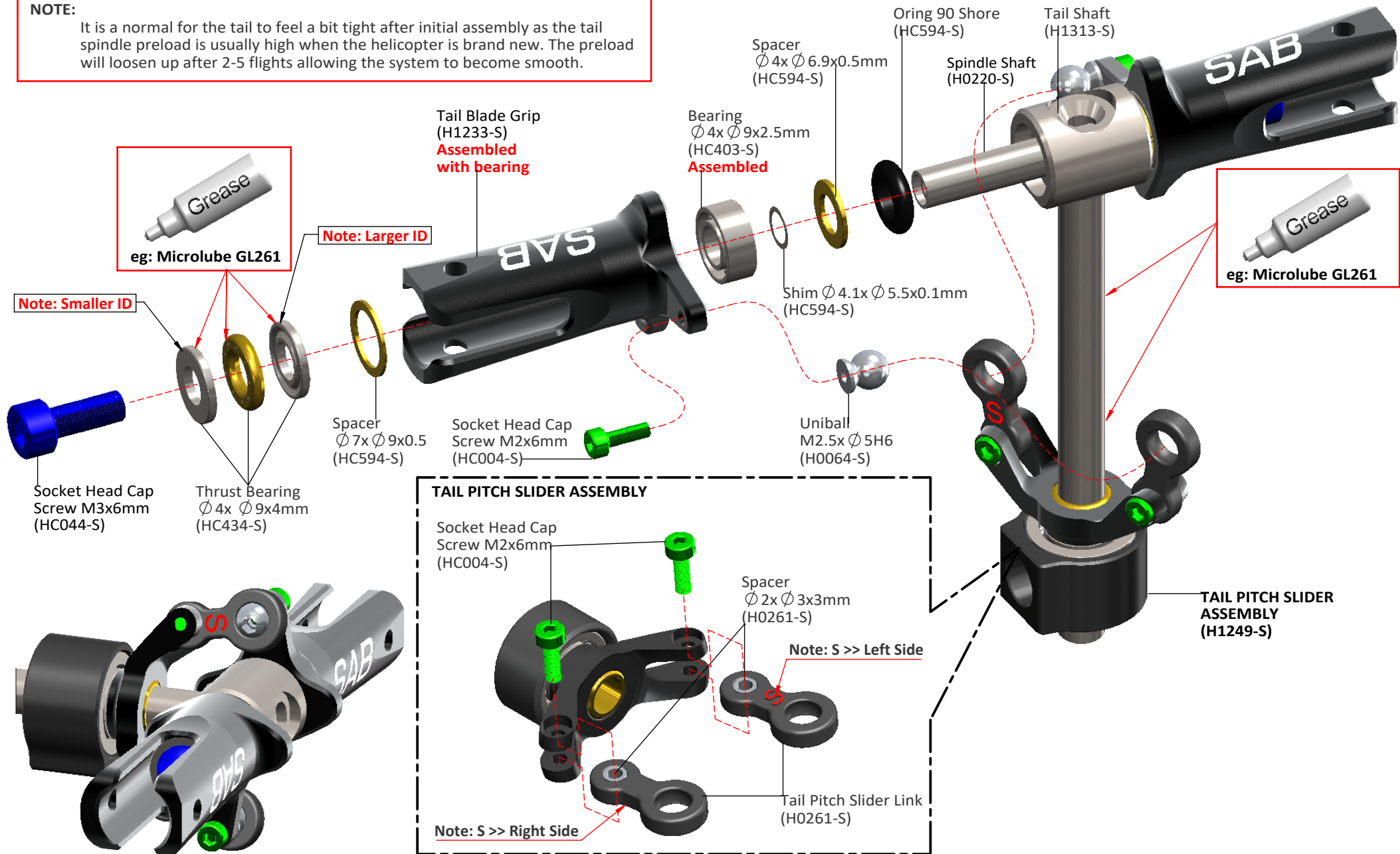

BOX 2, BAG FOR PAGE 27

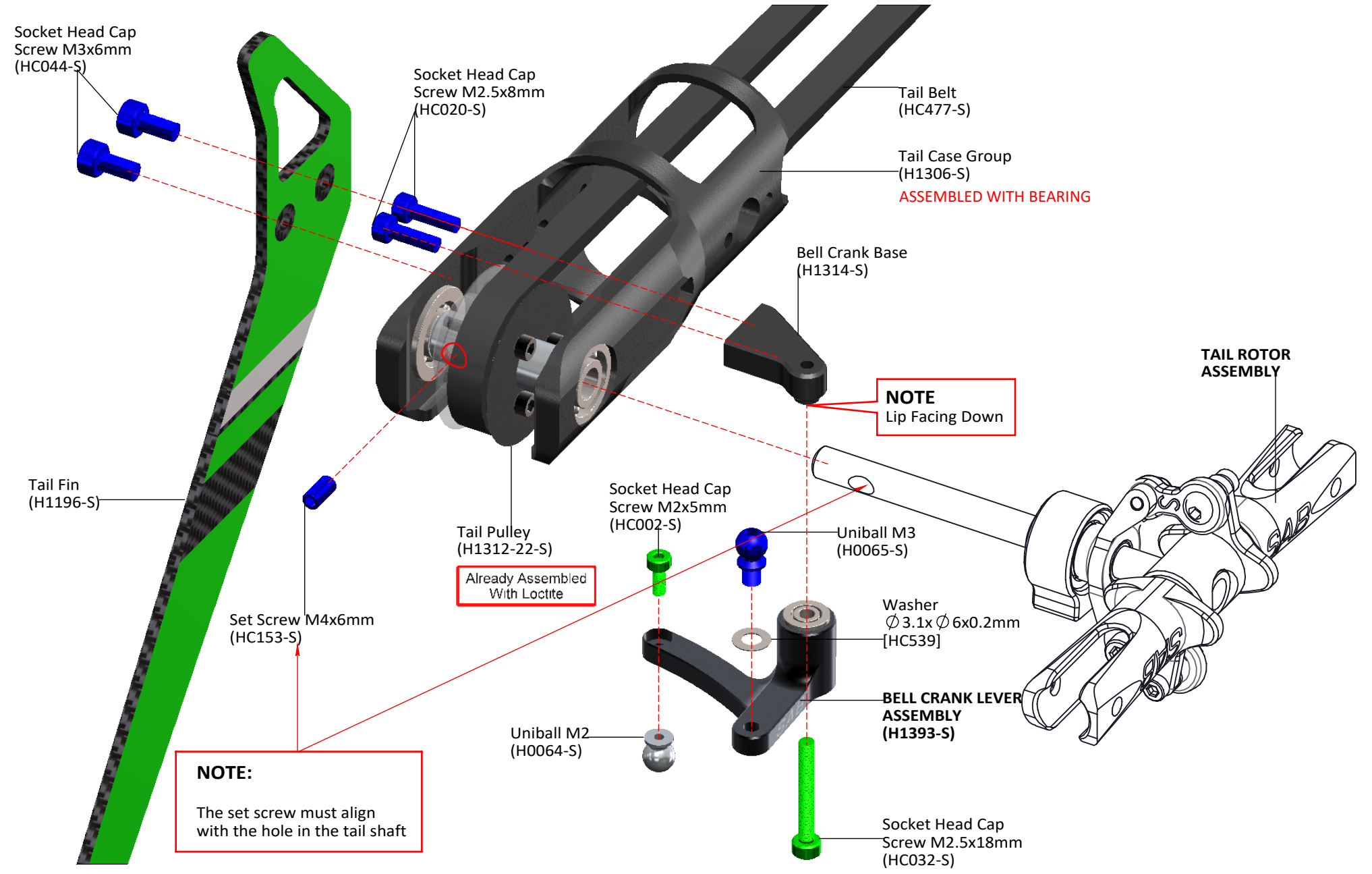

BOX 4, BAG FOR PAGE 28

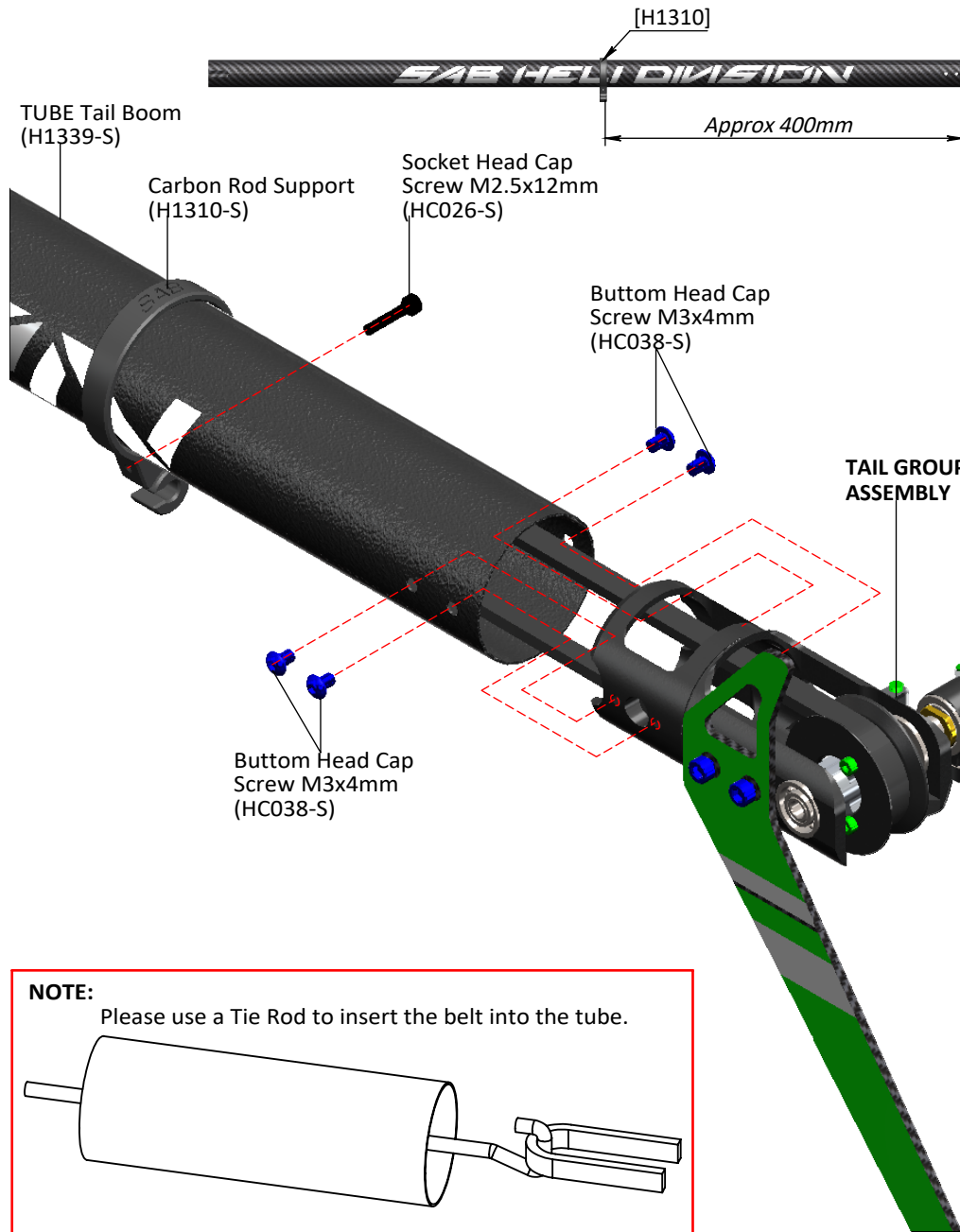

TAIL SERVO ASSEMBLY

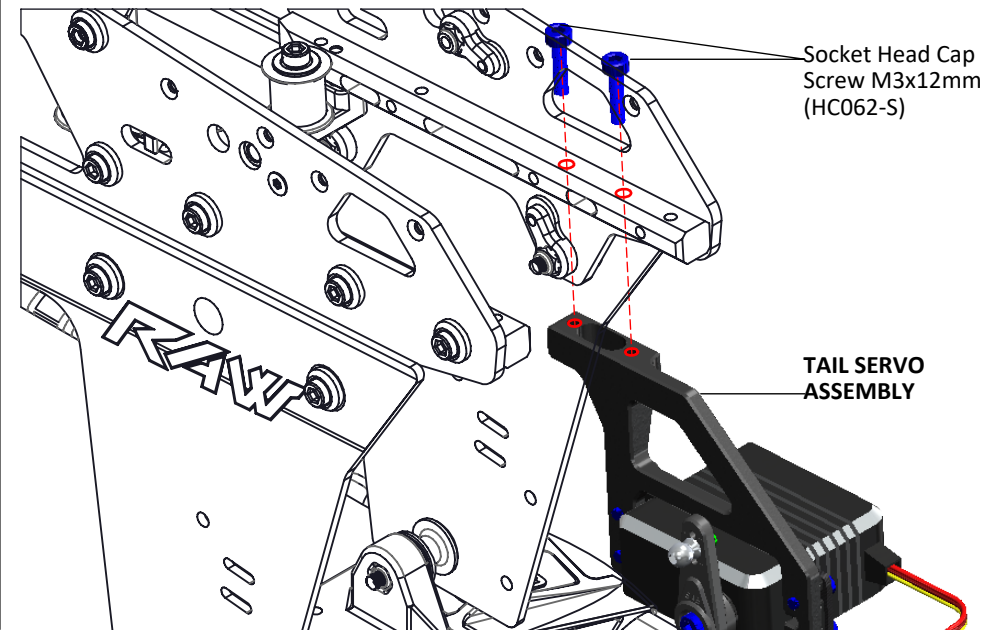
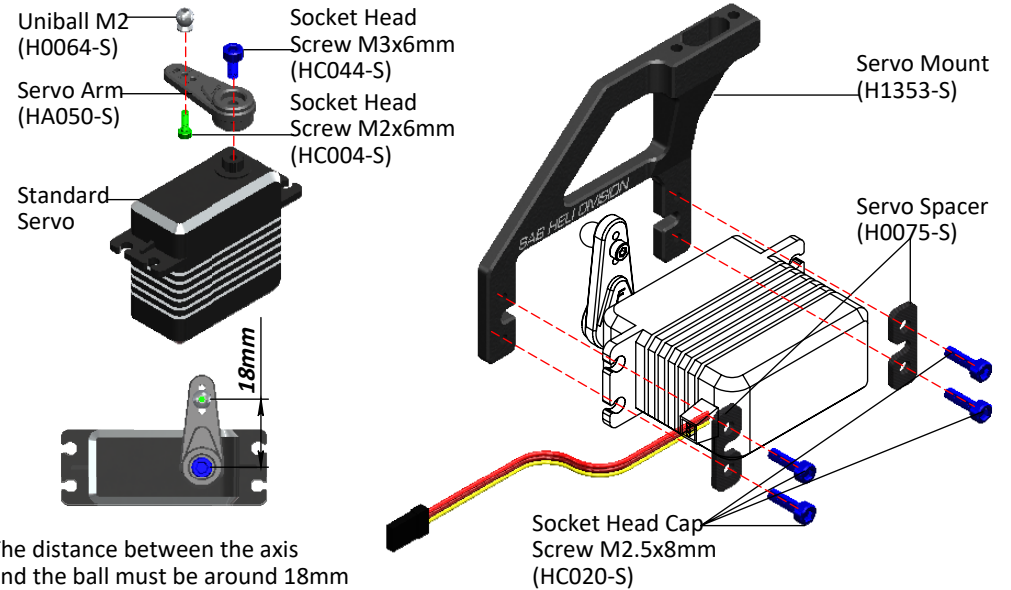

BOX 2, BAG FOR PAGE 29

BOOM BLOCK ASSEMBLY

NOTE: Do not tighten the M3x12 at this moment.

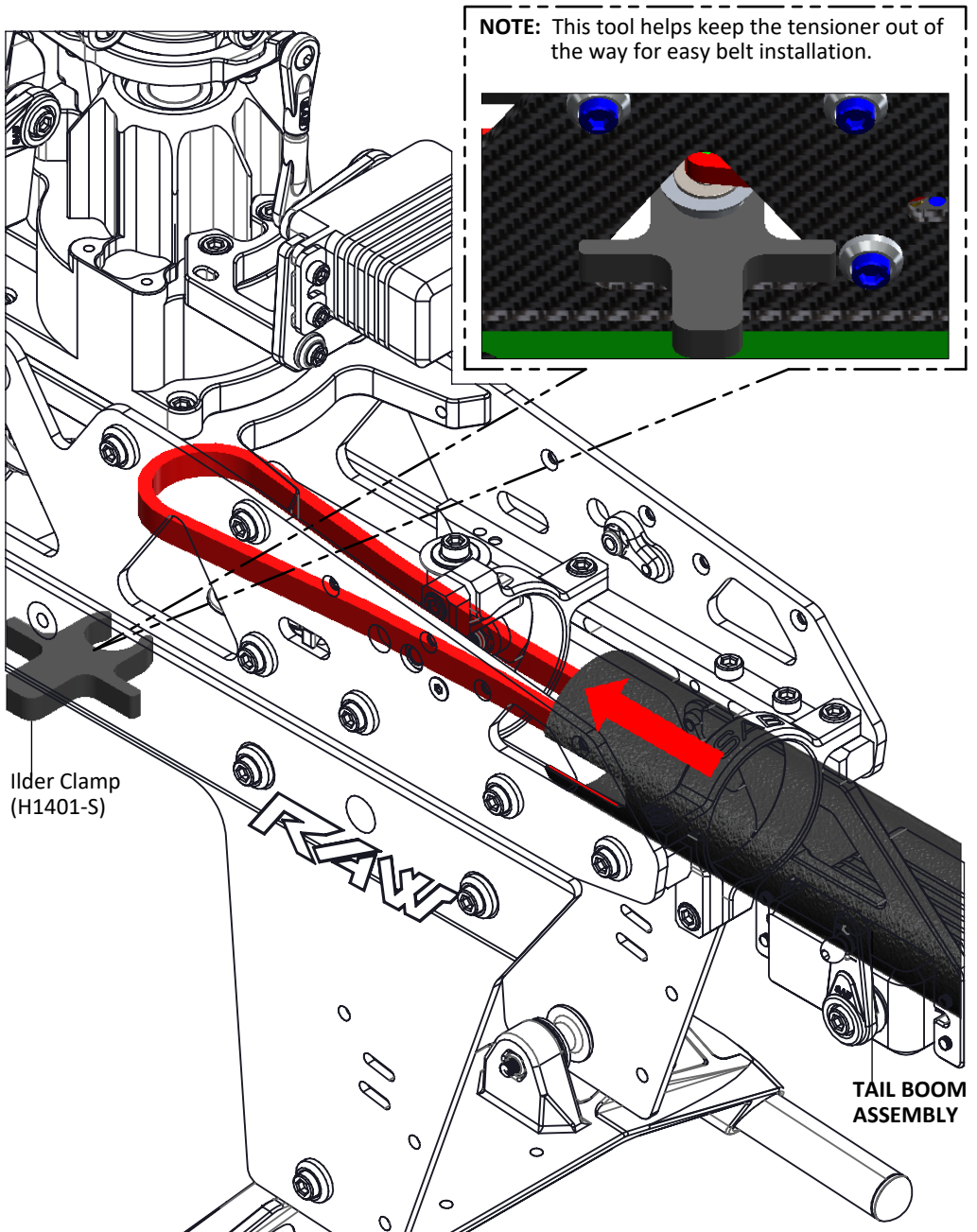
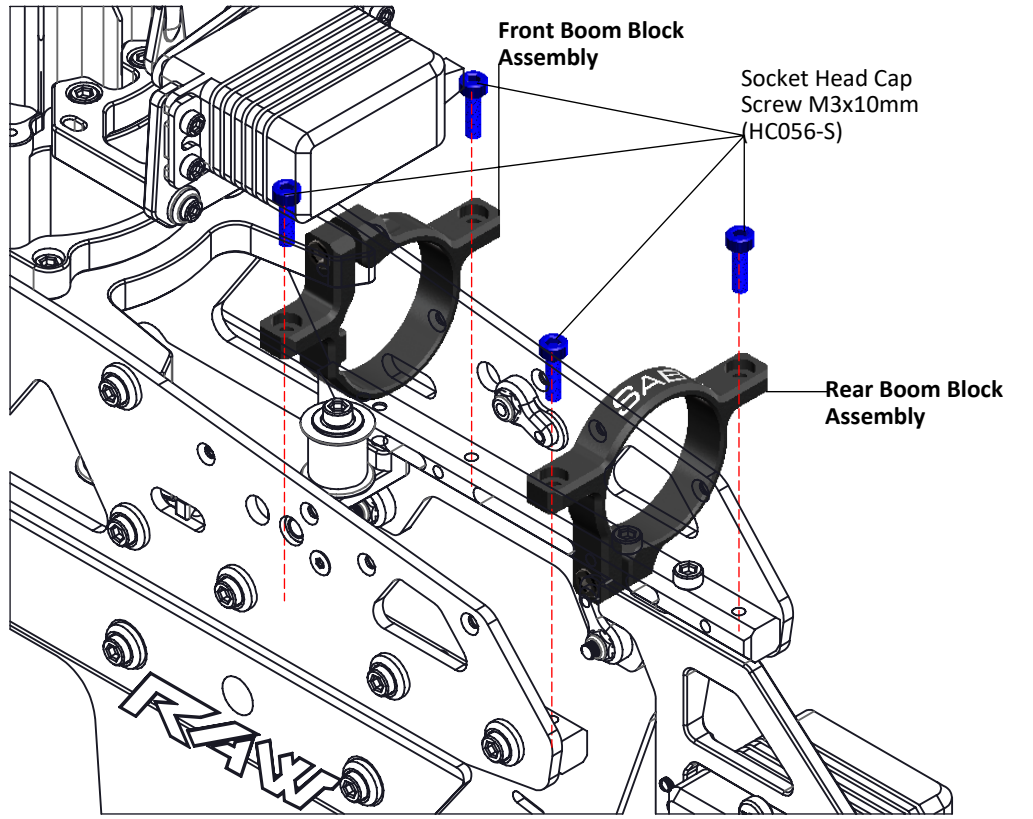
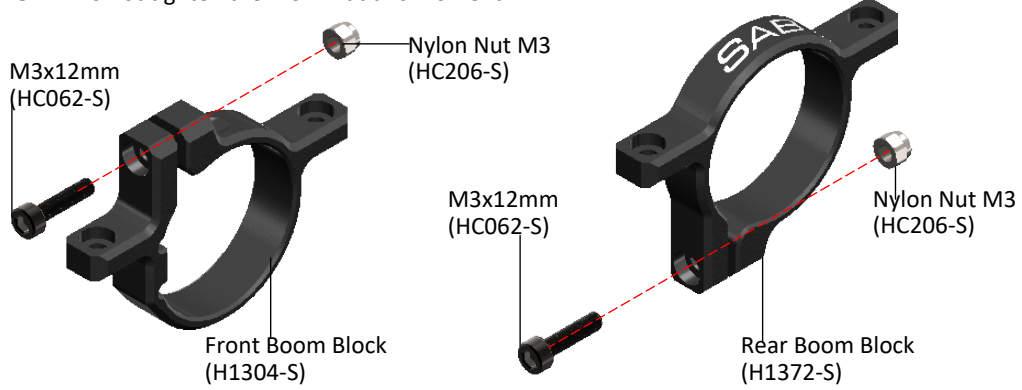

TAIL BOOM ASSEMBLY

To fit the tail belt, loosen the tail boom by loosening the 2 M3 screws (Fig.1).

*Install the belt onto the tail front pulley, checking the direction of rotation.

*Rotate the tail drive several times by hand.

*Tension the tail belt by using the tool kit to slide the boom backwards. Then slowly tighten the two red screws.

How to use the tail belt tension tool:

1. Push the plastic pad into its seat by unscrewing the orange M4x10 screw.
2. Install the tool on the boom, it needs to touch the H1371 clamp.
- The yellow M3 set screw can be used to make sure the tool is parallel to the boom clamp.
3. Tighten the pink M4x10 screw to lock the tool onto the boom.
4. Turn the orange M4x10 screw to tension the tail belt.
- This will push the boom back, thus tightening the tail belt.
5. Once the correct tension is achieved, tighten the two boom clamps with the two M3 screws.
6. Remove the tool before flight.

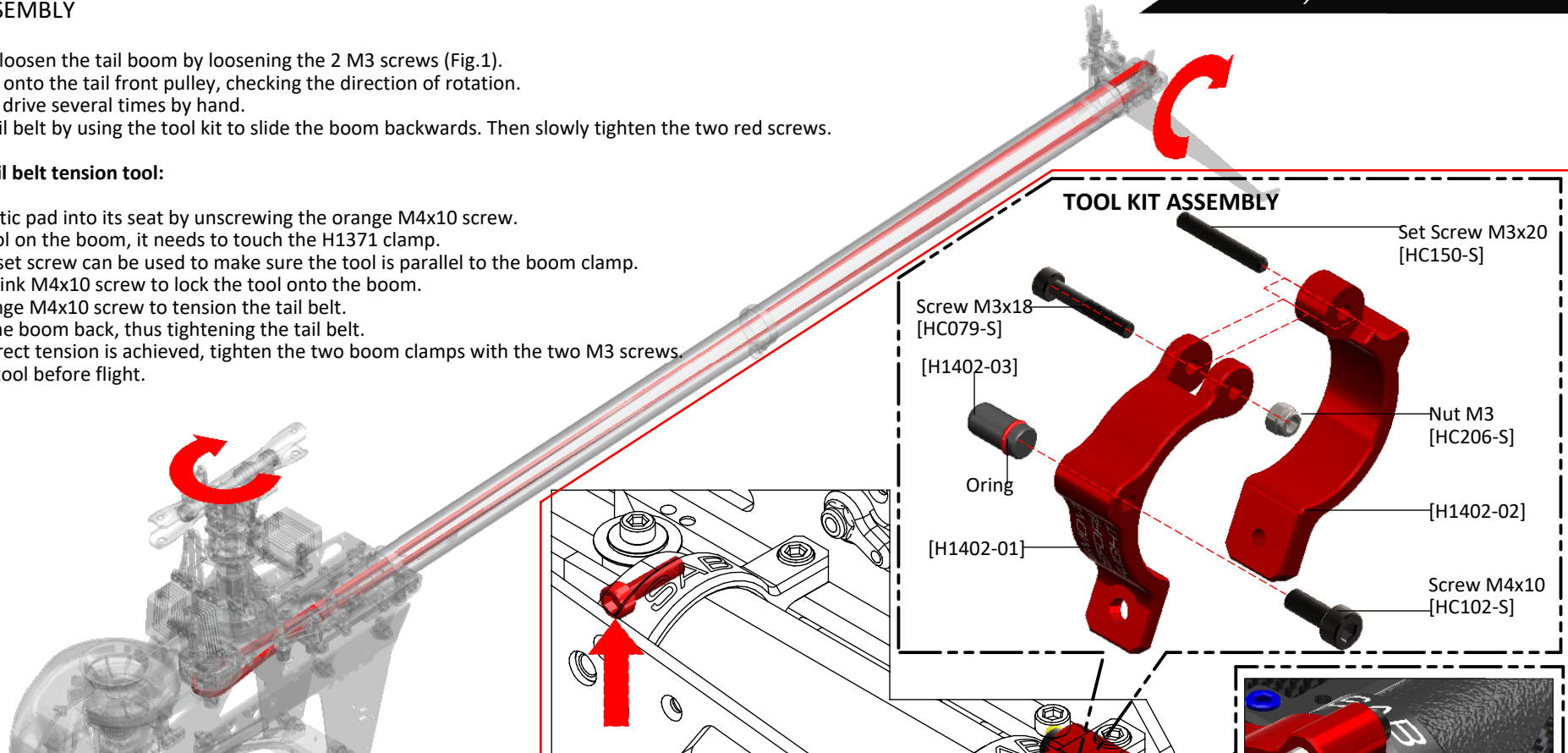

TOOL KIT ASSEMBLY

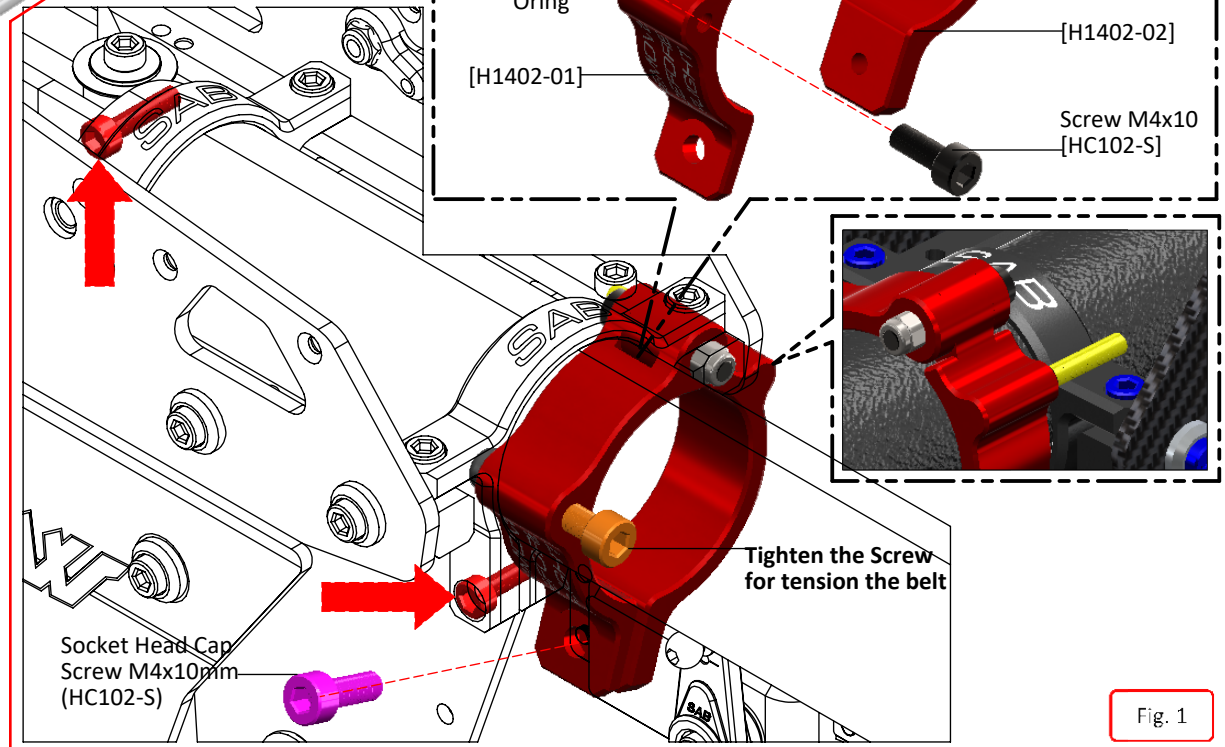
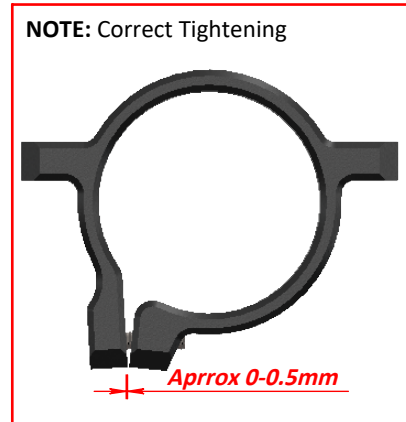
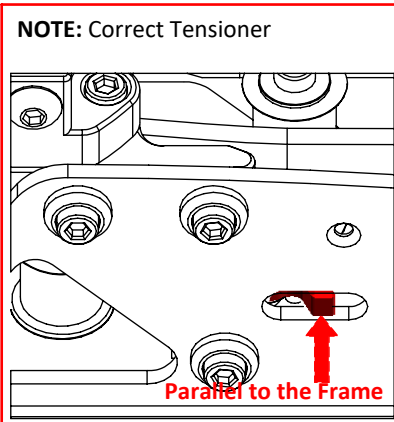
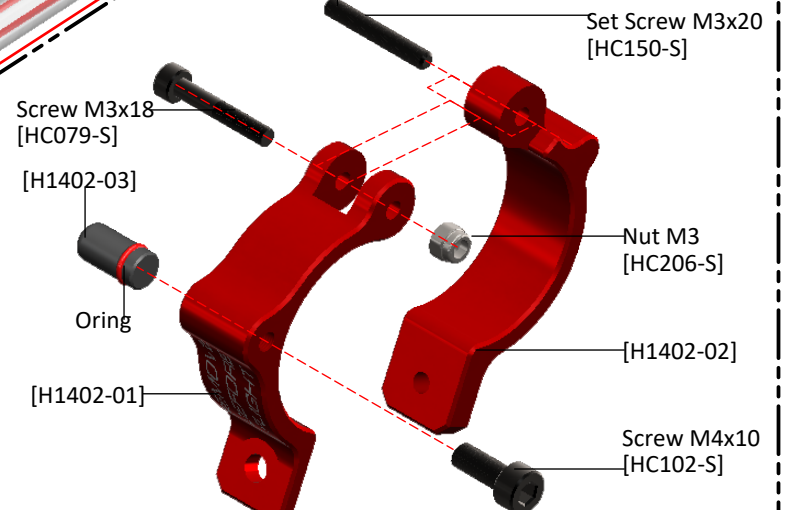
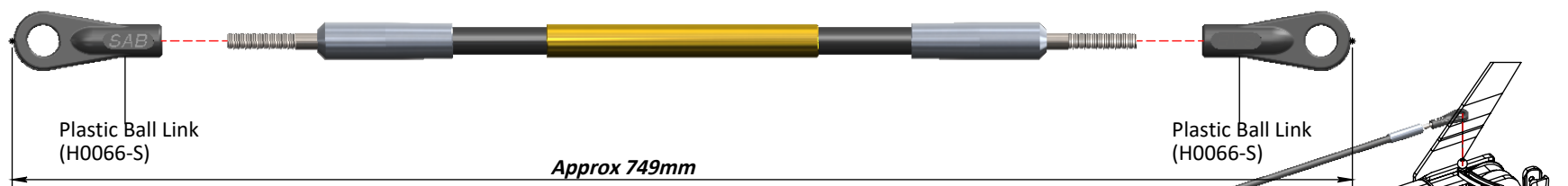

Fig. 1

BOX 2, BAG FOR PAGE 31

Before installing the plastic link on the threaded rod, be sure that you have waited at least 12 hours for the glue to fully cure.



NOTE: Before installing the plastic link onto the ball, be sure the tail push rod moves smoothly. You can open up H1310-S if you need to.

NOTE: The carbon rod is slightly bent, generating a little preload against the carbon rod support.

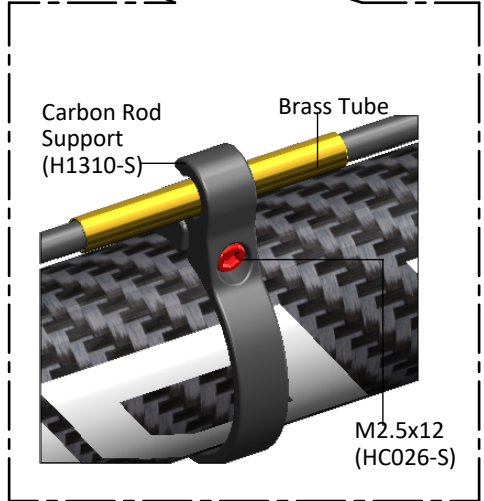
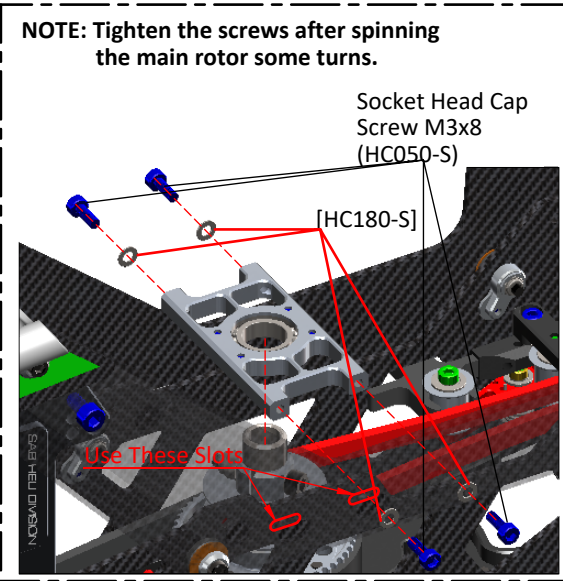
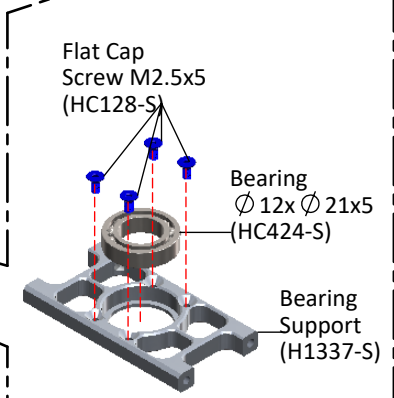
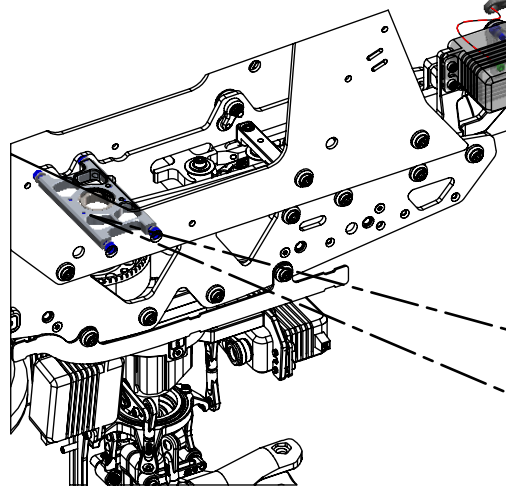

TANK LINE ASSEMBLY

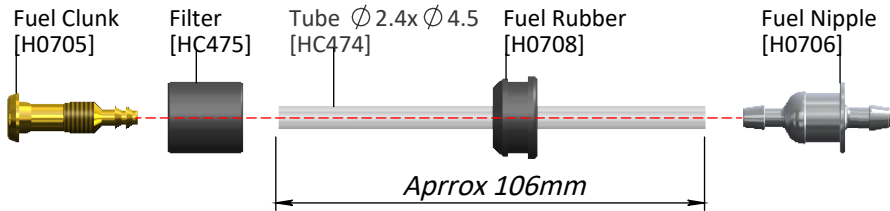

NOTE:
Install the fuel grommet into the tank, then gently insert the fuel nipple into the grommet.

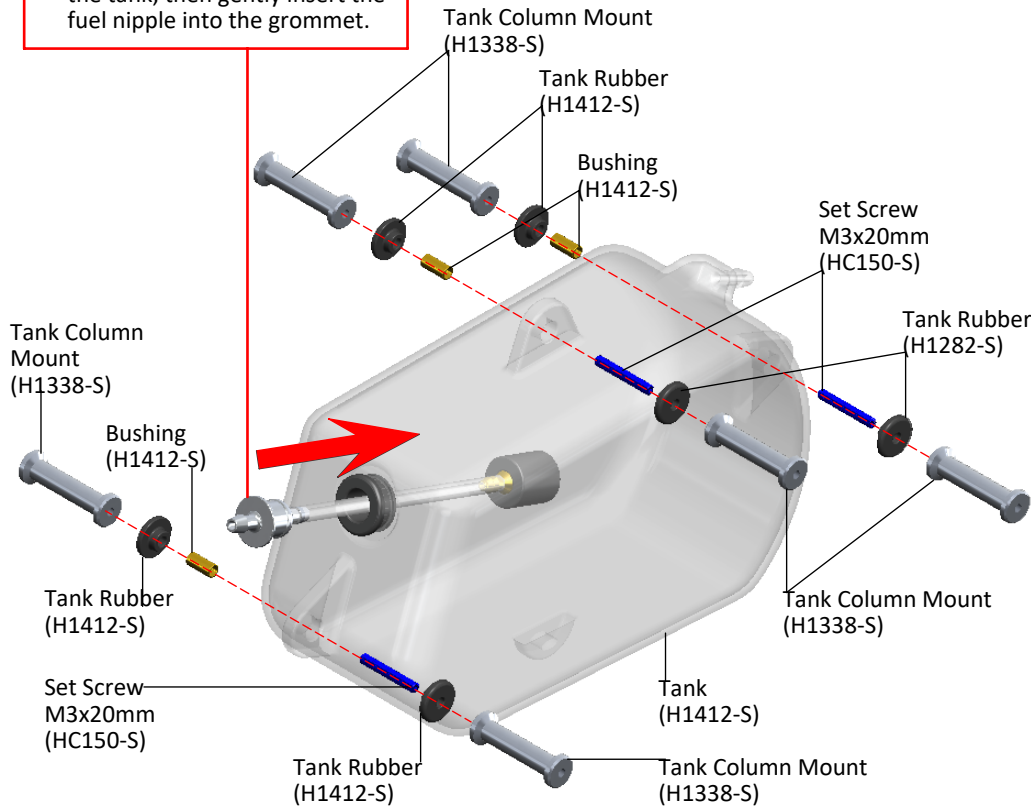

TANK GROUP ASSEMBLY

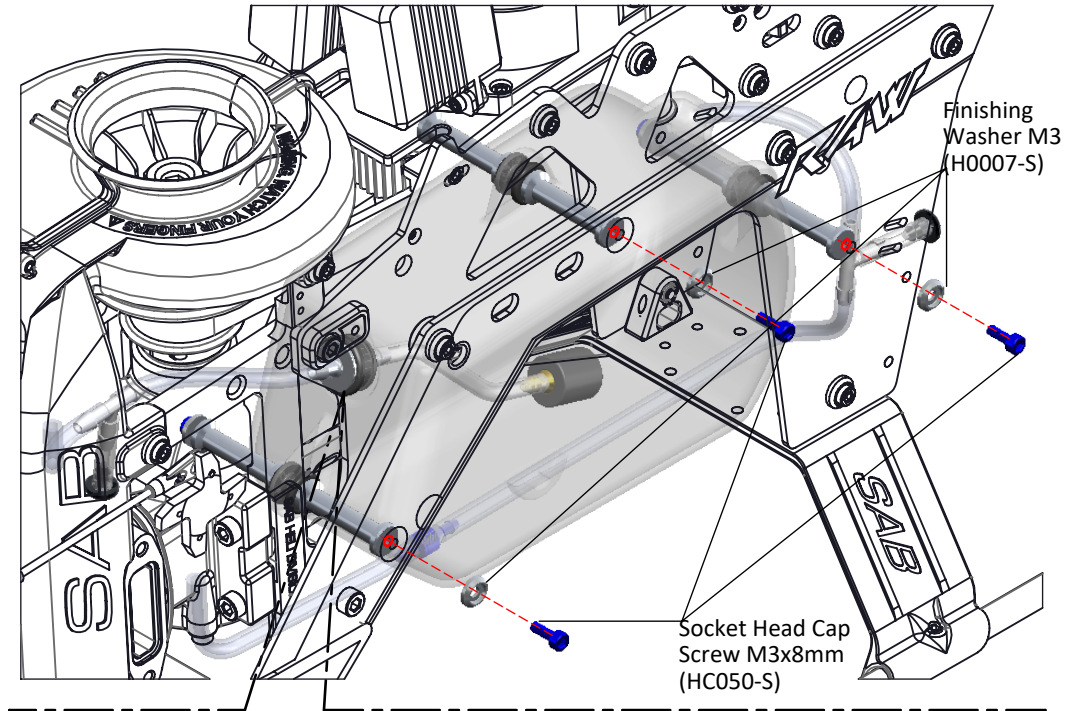

NOTE: Only use a backplate pressurized tank setup if your engine supports it. Consult your engine manual before plumbing your tank in this way.

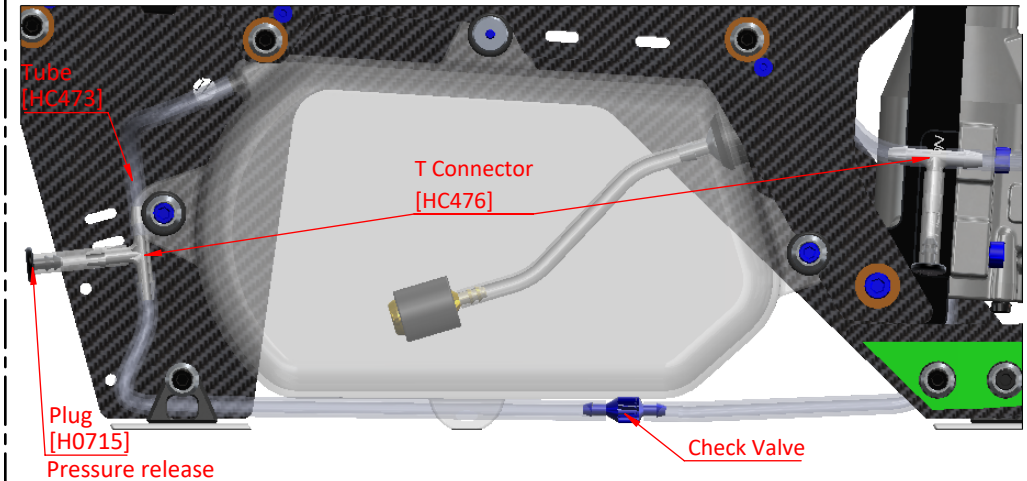

BOX 2, BAG FOR PAGE 33

FBL PLATE ASSEMBLY

NOTE: 2mm thick tape for the gyro is recommended.

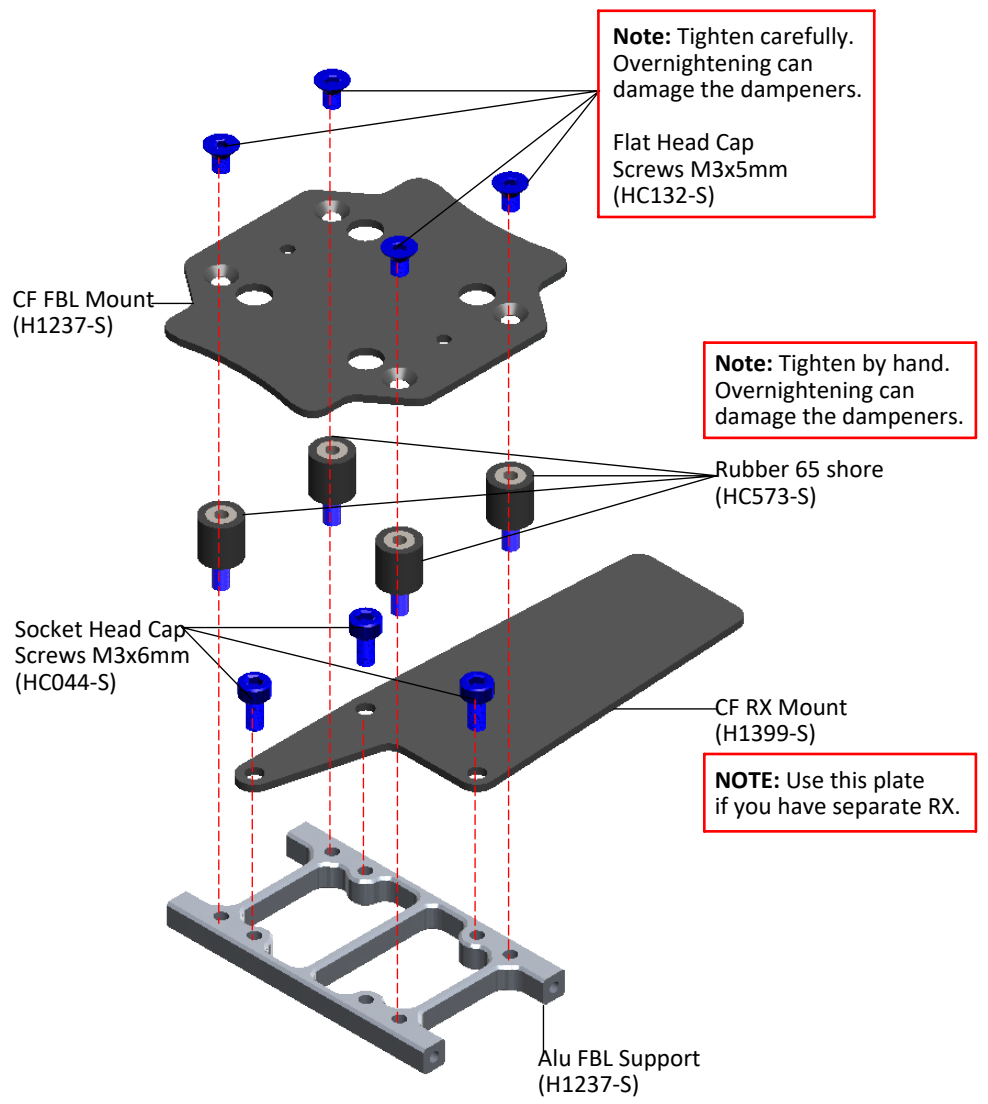

If you do not want to use the dampeners, you can setup a rigid FBL mount support using the screws and bushings supplied in bag 33-2

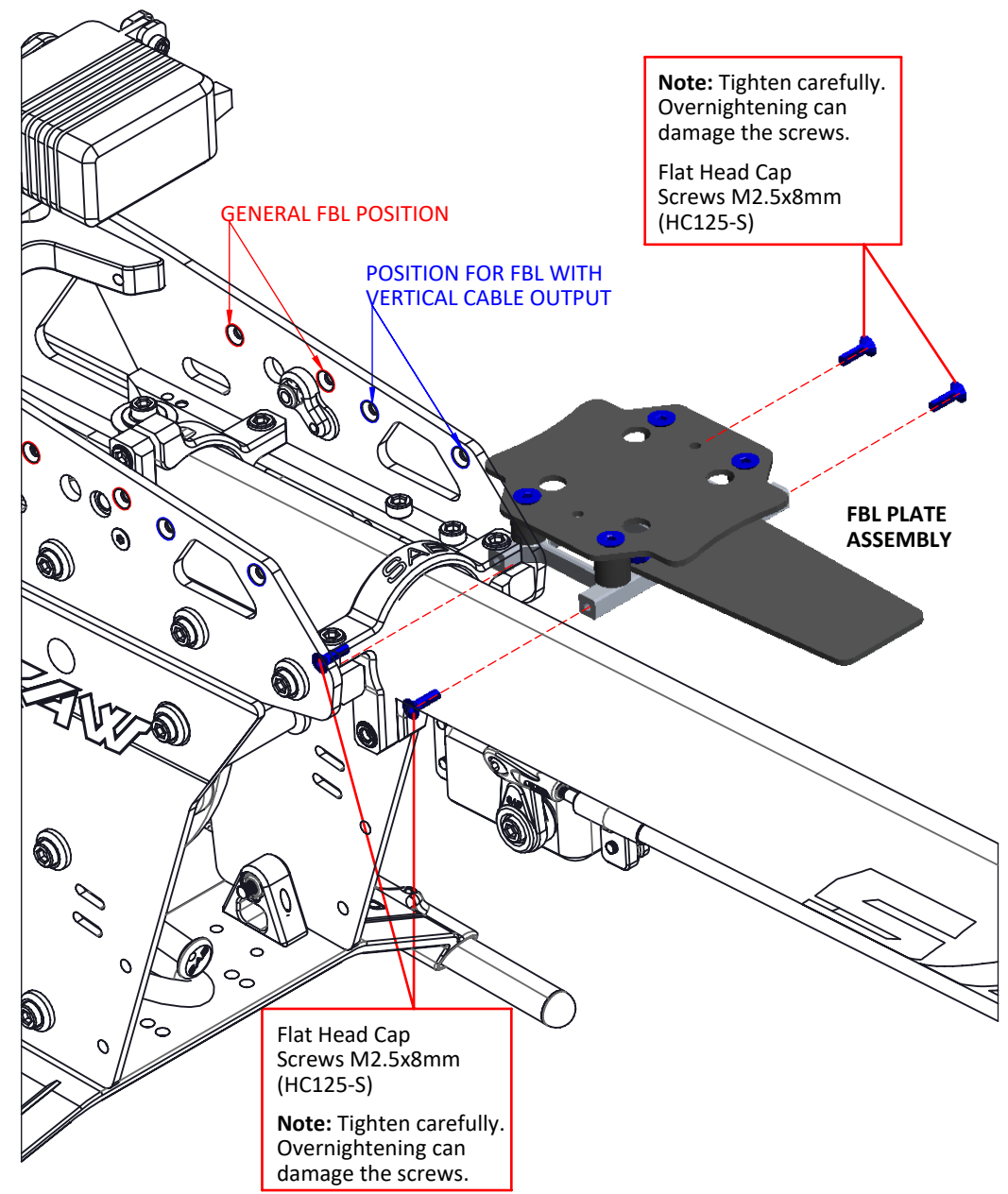

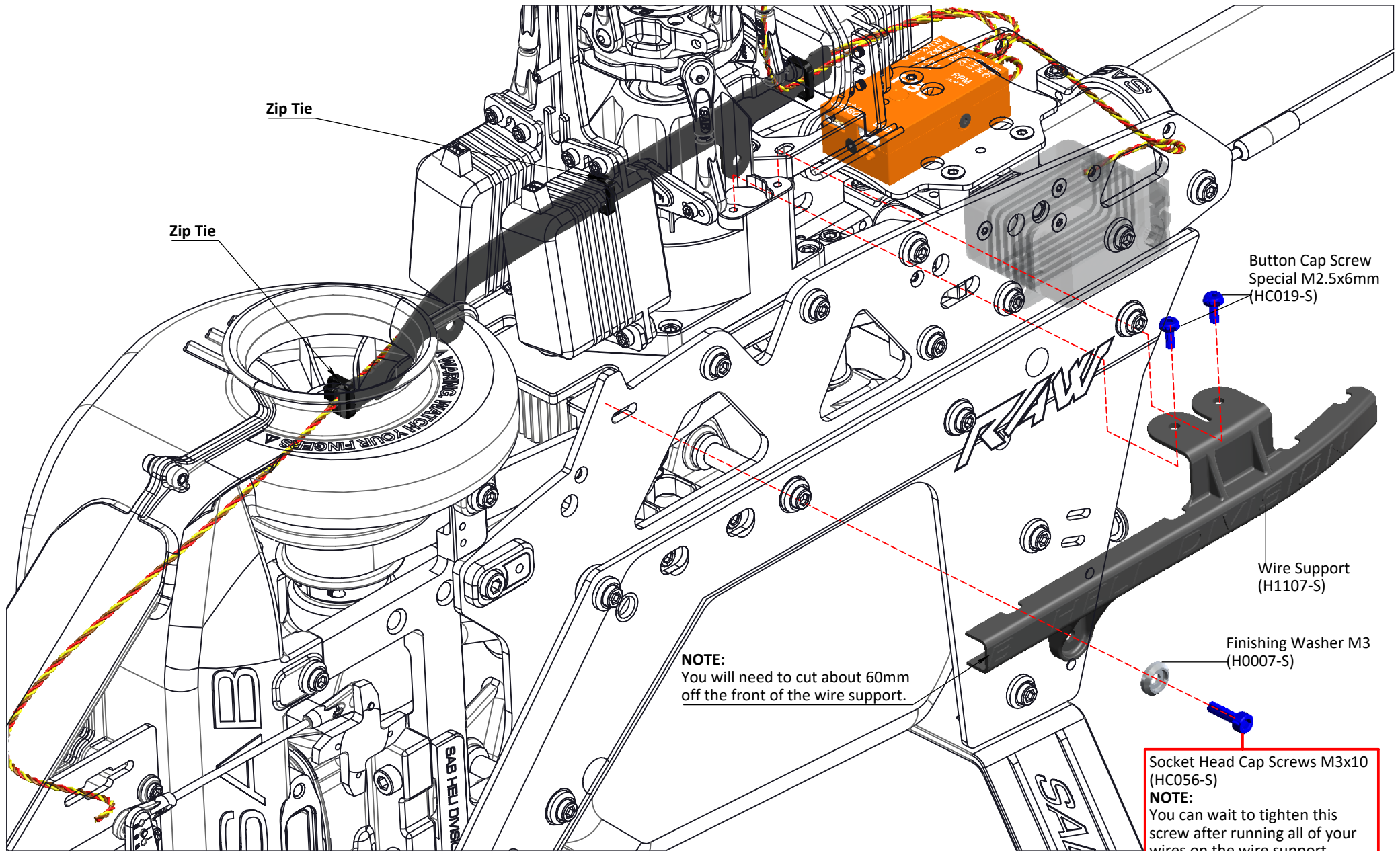

BOX 2, BAG FOR PAGE 35

In bag 35, you can find a "3D Printed" antenna support. Use it as desired with your RX system.

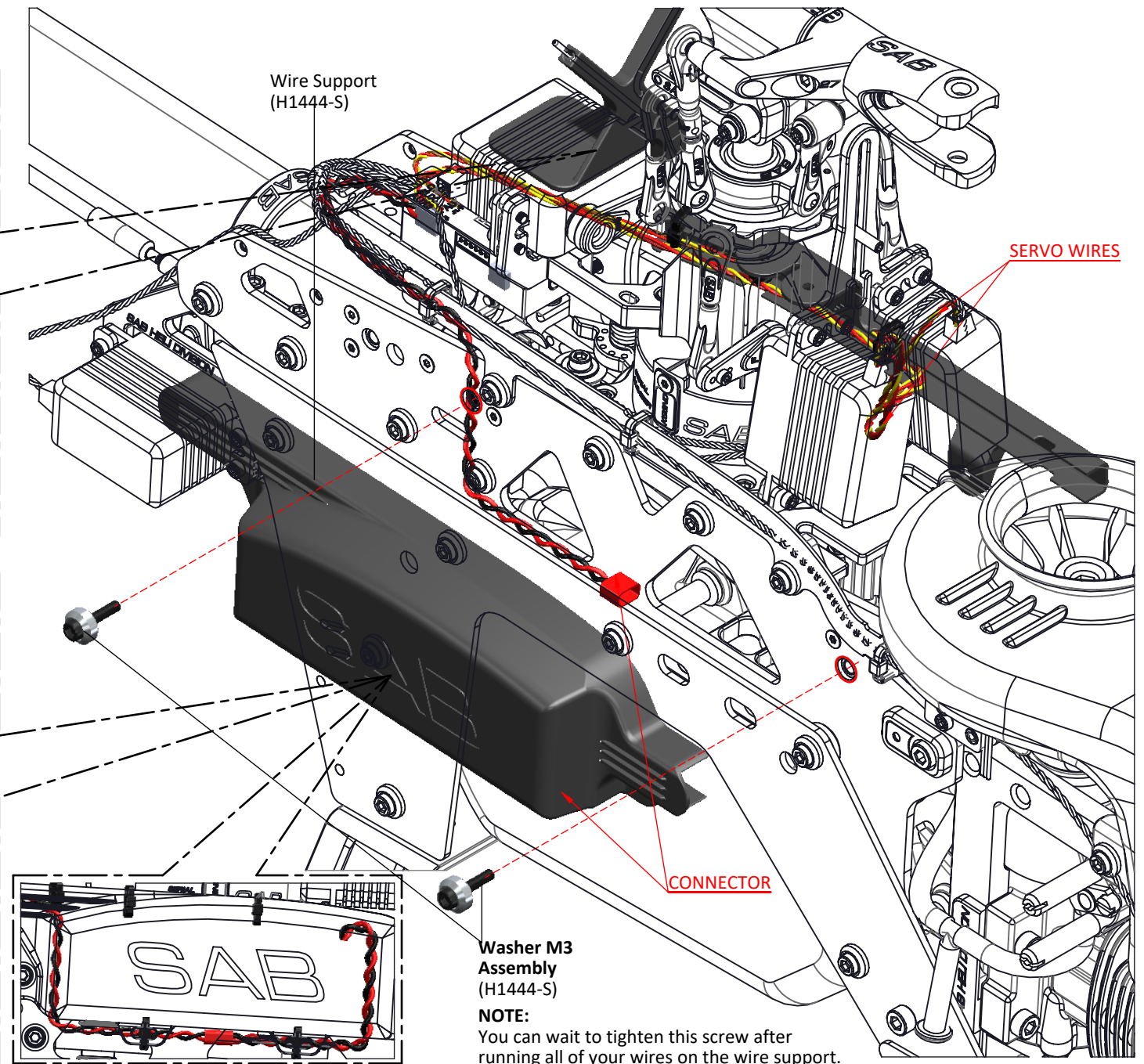
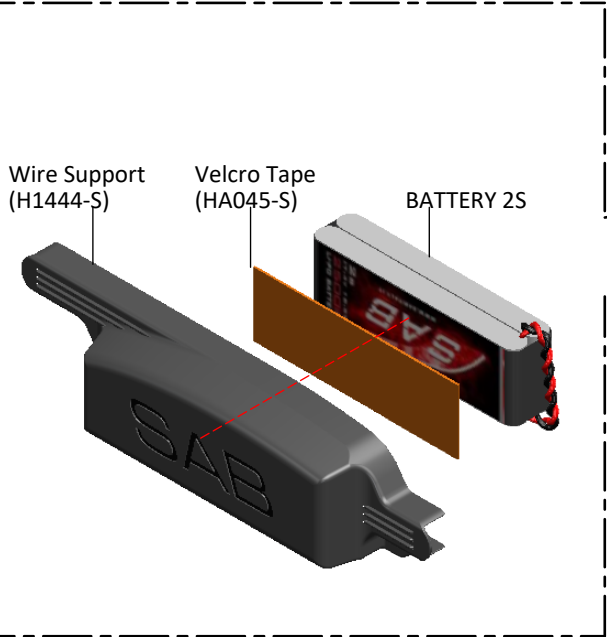
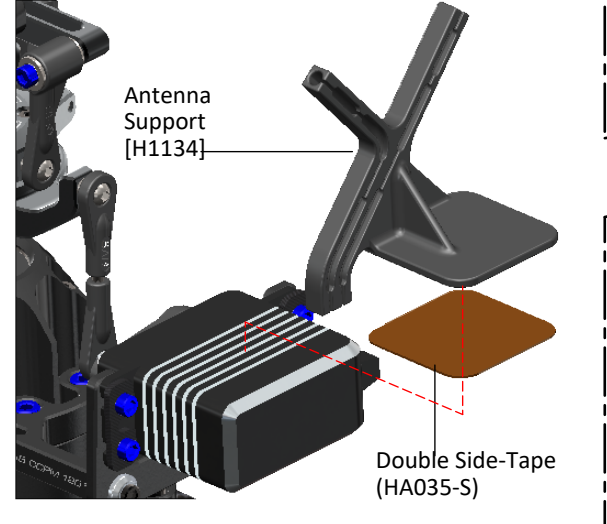

NOTE:
You can wait to tighten this screw after running all of your wires on the wire support.

CANOPY

*Put canopy and move as (Figure.1) and installation screw (Figure.2)

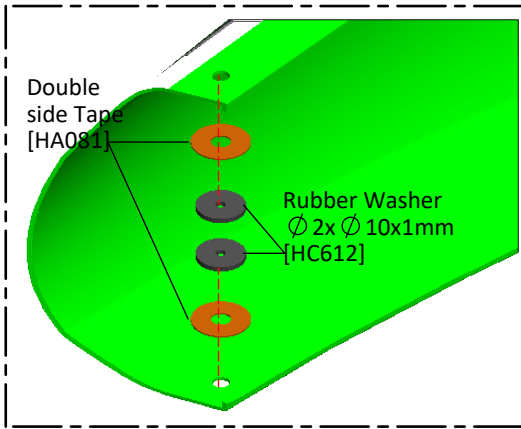
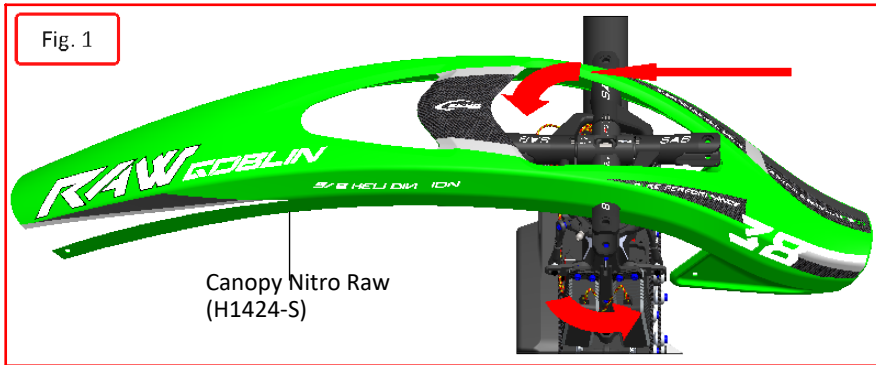

Socket Head Cap Screw M3x12mm (HC062-S)

Finishing Washer M3 (H0007-S)

Fig. 2

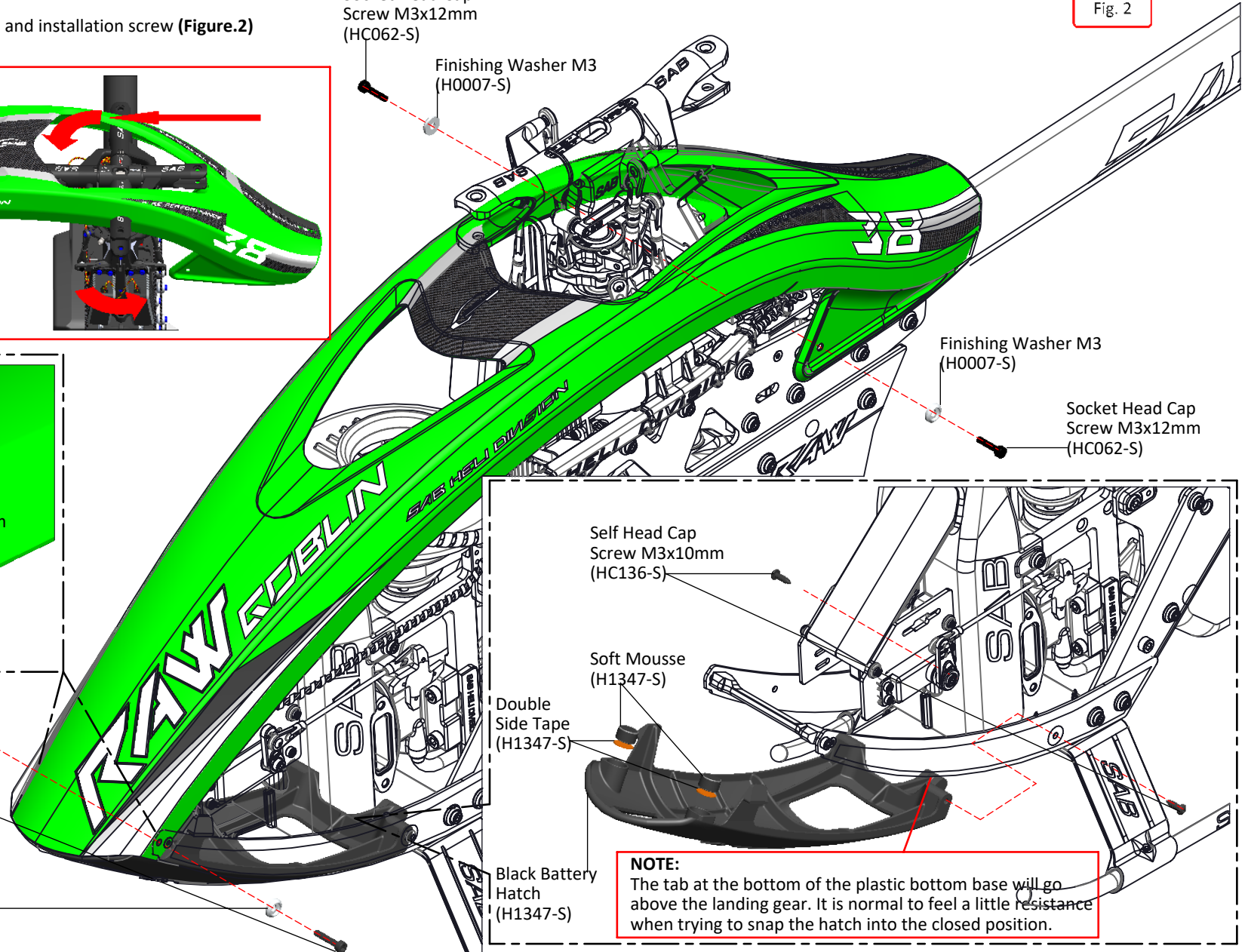

NOTE:
The tab at the bottom of the plastic bottom base will go above the landing gear. It is normal to feel a little resistance when trying to snap the hatch into the closed position.

BOX 2, BAG FOR PAGE 37

OPERATIONS BEFORE FLIGHT

- *Set up the remote control and the flybarless system with utmost care.
- *It is advisable to test the correct settings of the remote and flybarless system without main blades or tail blades fitted.
- *Check that all wiring is isolated from the carbon/aluminum parts. It is good practice to protect them at the points where they are at most risk.
- *Be sure of the gear ratio, verifying carefully the engine pulley in use. The forces acting on the mechanics increase enormously with increasing of rpm. Although the Goblin can fly at high rpm, for safety reasons we suggest to not exceed 2000rpm.
- *Fit the main blades and tail blades. (Figure.1 and Figure.2)
- *Please make sure the main blades are tight on the blade grips, you should be able to violently jerk the head in both directions and the blades should not fold. Failure to tighten the blades properly can result in a boom strike. To fold the blades for storage, it is advisable to loosen them.
- *Check the collective and cyclic pitch. For 3D flight, set about +/-13°.
- *It is important to check the correct tracking of the main blades. On the Goblin, in order to correct the tracking, adjust the main link rod. This is provided with a right/left thread system that allows continuous fine adjustments of the length of the control rod; for this adjustment it is not necessary to detach the ball link.
- *Confirm the canopy is secure prior to each flight.
- *Perform the first flight at a low headspeed, 1600 RPM.  After this first flight, do a general check of the helicopter. Verify that all screws are correctly tightened.

IN FLIGHT

ABOUT HEAD

The HPS head allows for a very broad range of dampening setups. The dampers are composed of 3 O-ring (that defines the rigidity) and a technopolymer damper (that defines the maximum possible movement of the spindle). Using different Oring and dampers you can get different responses of the model.

Oring

- 80 Shore: Soft for smooth response
- 90 Shore: Firm for direct and precise response
- A = Max movement of the spindle, feeling more elastic.
- B = Medium.
- C = Min movement of the spindle, feeling more direct.

The KIT include C damper and B damper.
Use C damper , if you have some wobble in flight you can change to the B damper.

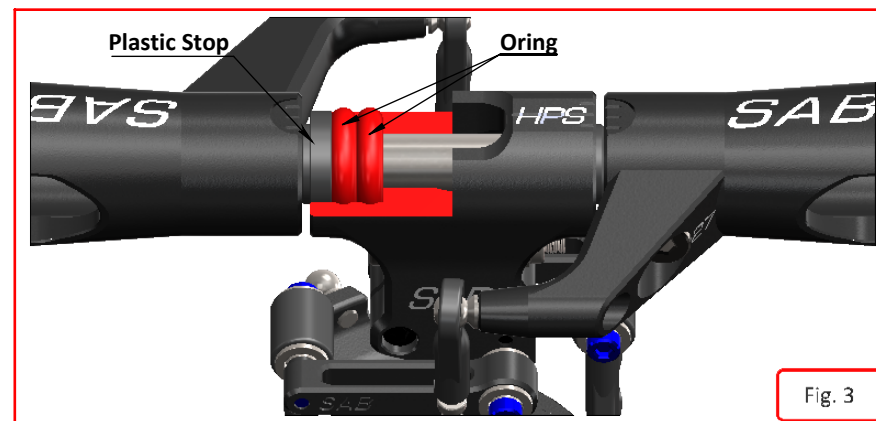
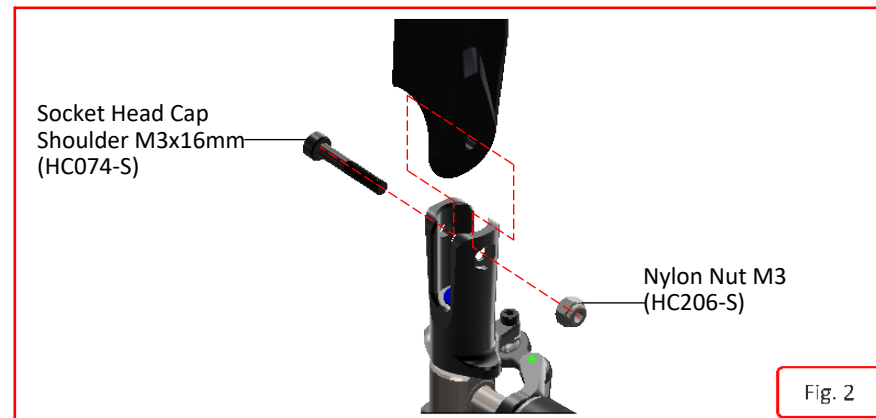
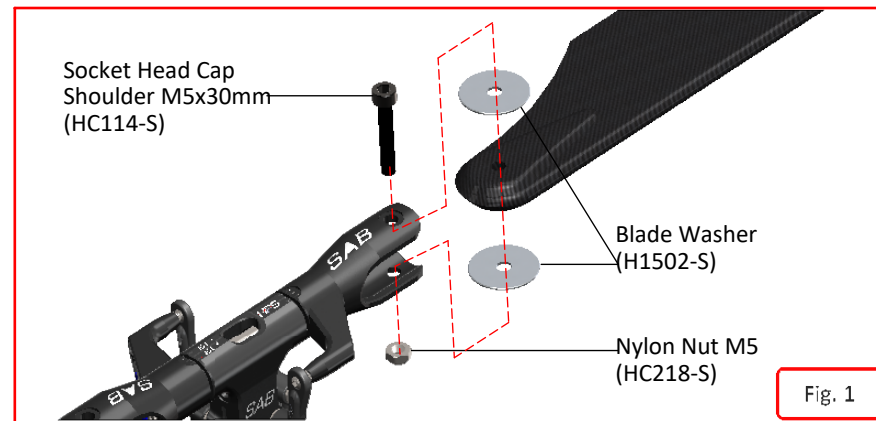

MAINTENANCE

Take a look at the red parts.

Check them frequently. All other parts are not particularly subject to wear.

The lifespan of these components varies according to the type of flying.

On average it is recommended to check these parts every 20 flights. In some instances, based on wear, these parts should be replaced every 100 flights.

Periodically lubricate the tail slider movement and its linkages as well as the swash plate movement and its linkages.

To ensure safety you should do a general inspection of the helicopter after each flight. You should check:

- Proper belt tension (engine belt and tail belt).
- Proper isolation of the wires from the carbon and aluminum parts.
- All screws and bolts remain tight.

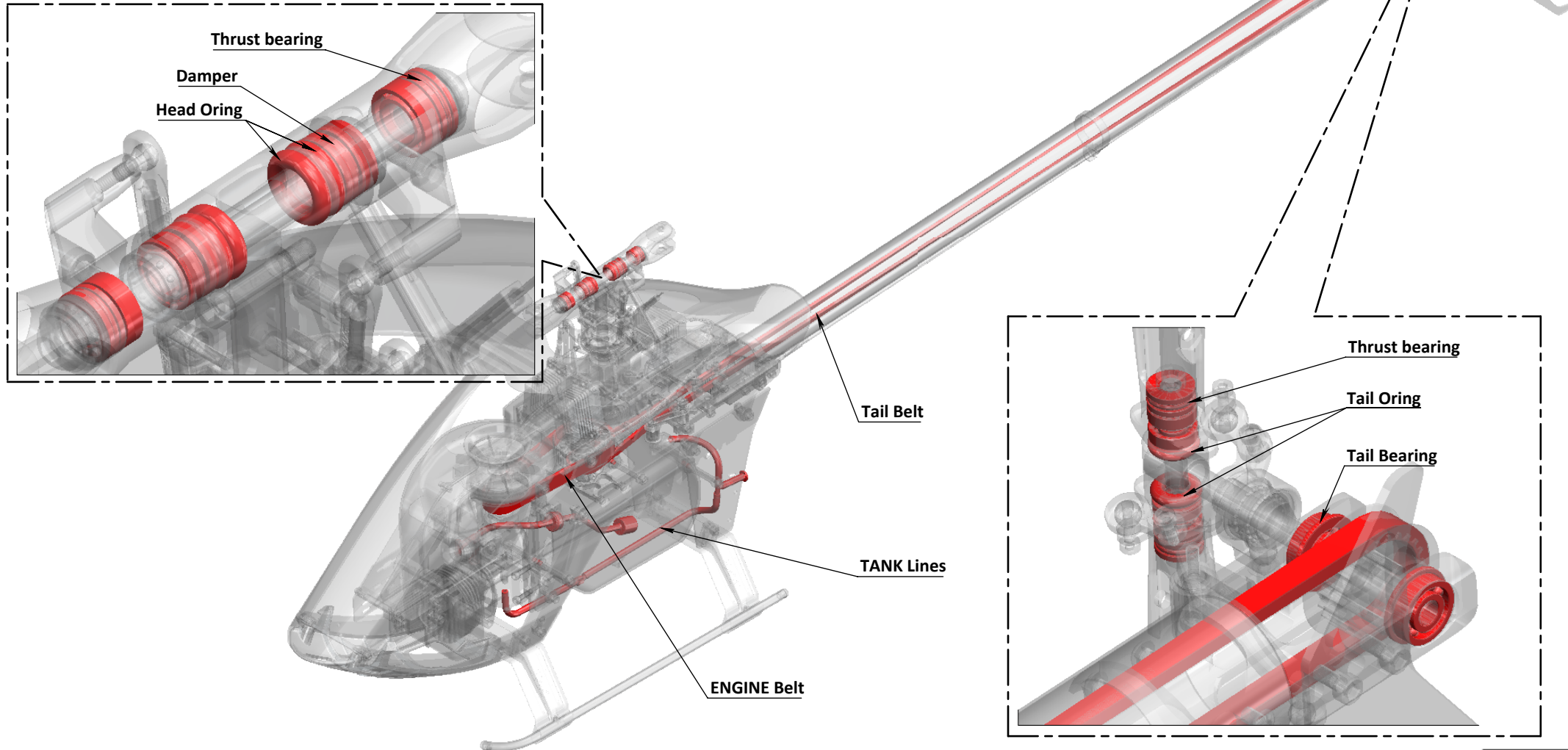

TRANSMISSION MODULE

The transmission module is supplied assembled and verified, ready to be used.

Explode and Spare Parts



NOTE:

Before to open the transmission module, use heat to neutralize the loctite. (example use a gas torch)

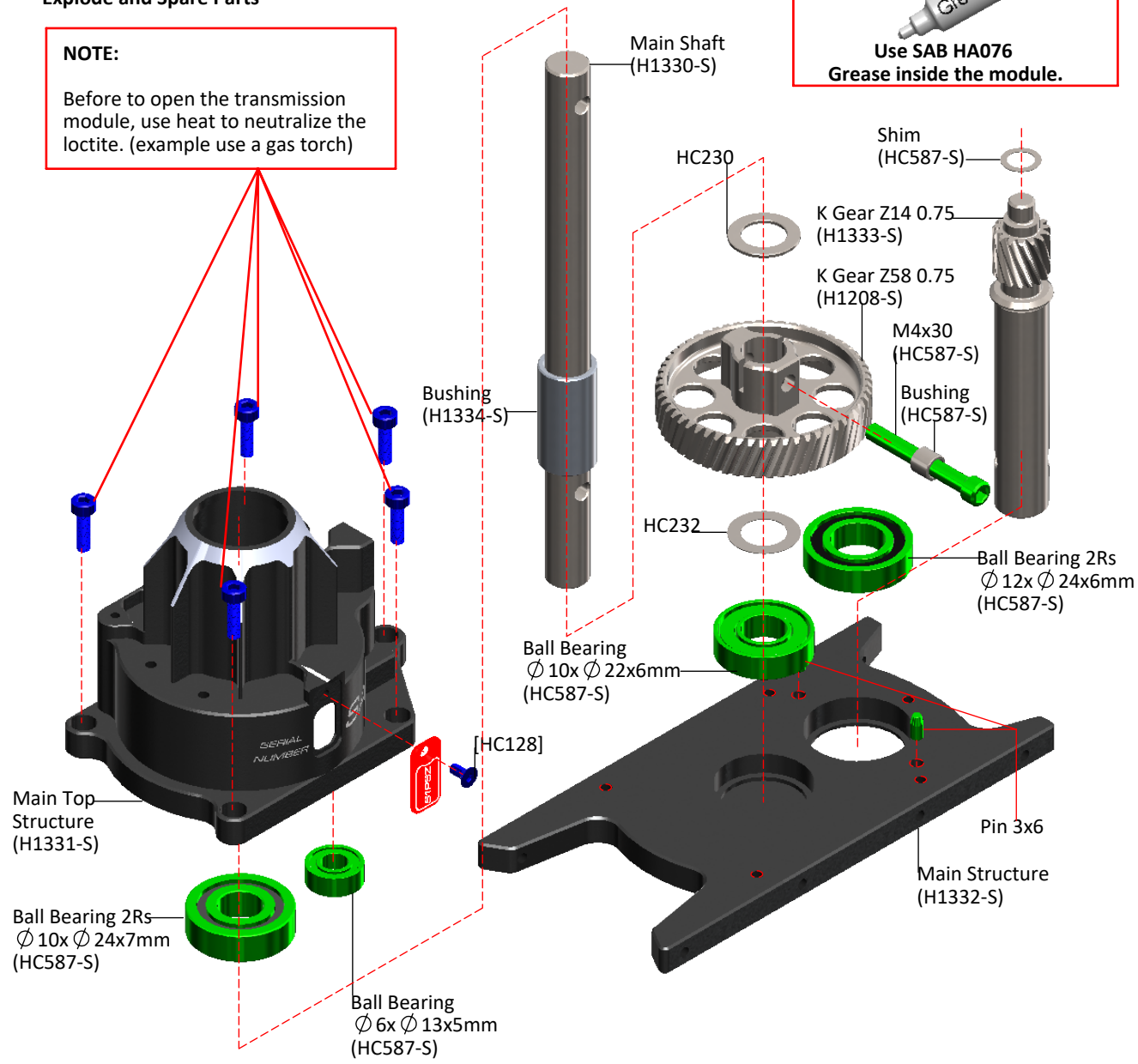

MAIN SHAFT REPLACEMENT

For replacing the main shaft:

- *Remove the serial number plate
- *Remove the M4 screw
- *Remove and replace the main shaft
- *Screw in the M4 screw, with high force and using green loctite

NOTE:
Before removing the M4 screw, use heat to break down the loctite. (example use a gas torch).

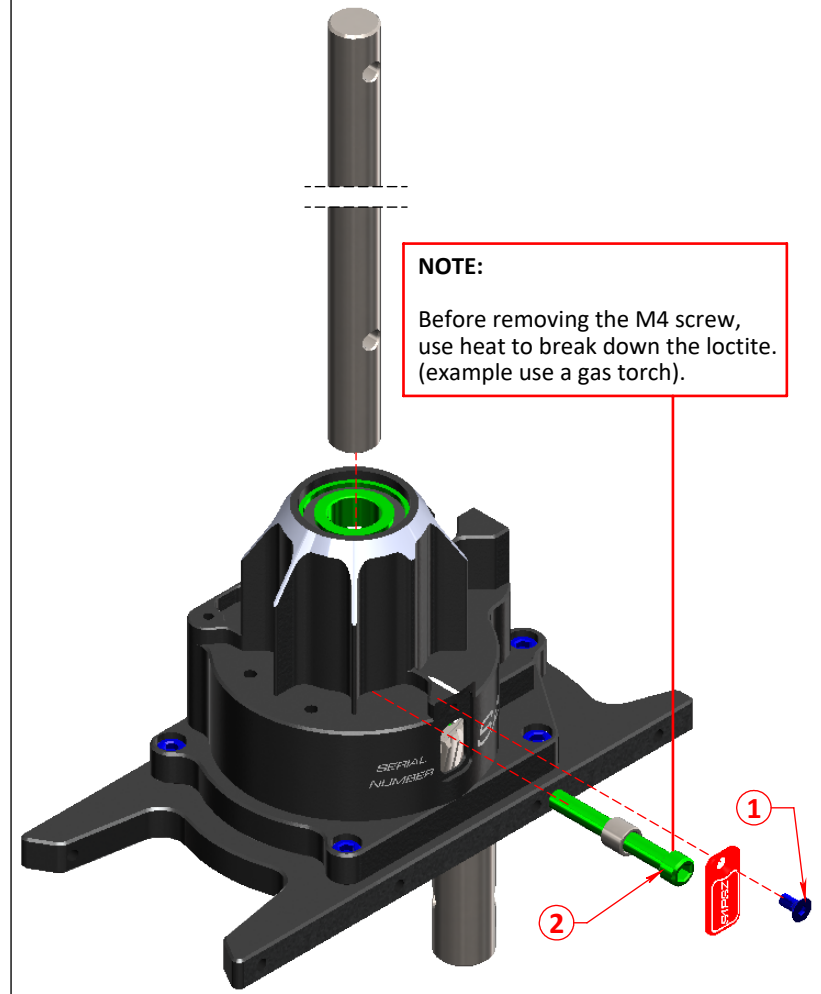

1 Check the dampening on the main and tail rotor to be the same as always.

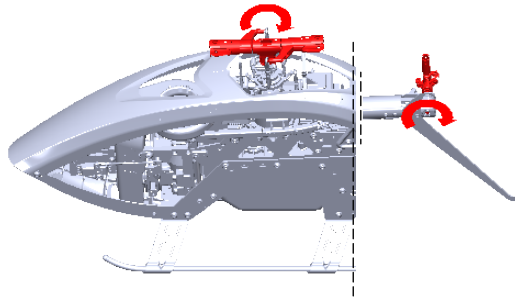

2 Tighten the main blades before flight.

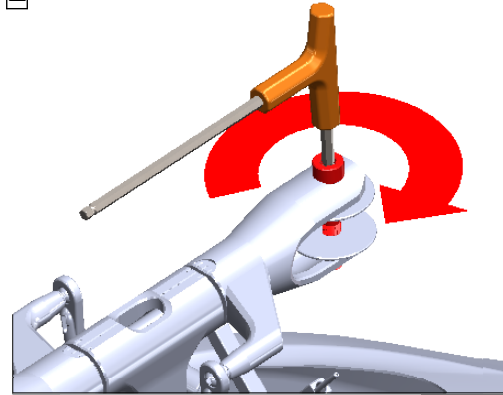

3 Check main hub screws(M4 and 2 M2.5) Ensure they are tight.

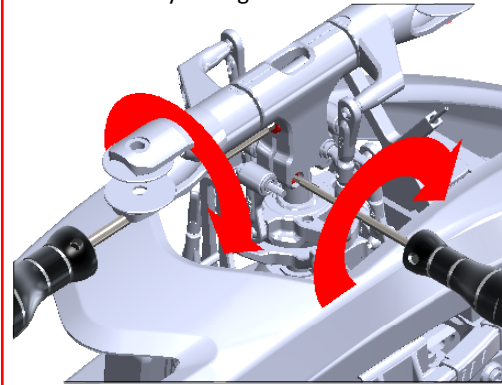

4 Check all Fuel Line (Good connection).

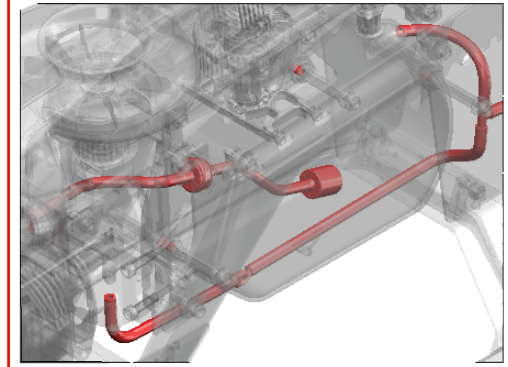

5 Check Tail & Engine belt tension. The tension has to be tight.

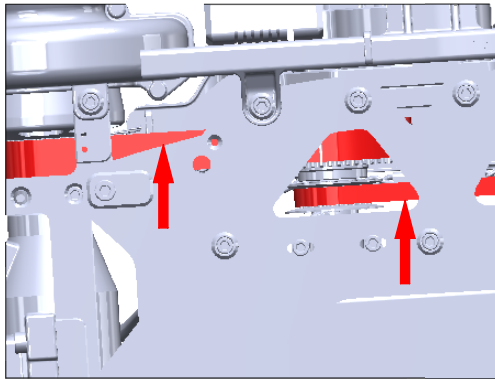

6 Check the 2 M3 screws in Clamp. Ensure they are tight.

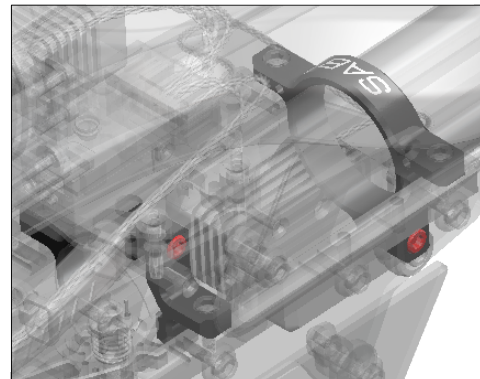

7 Check the Main Linkages & Servo Linkages

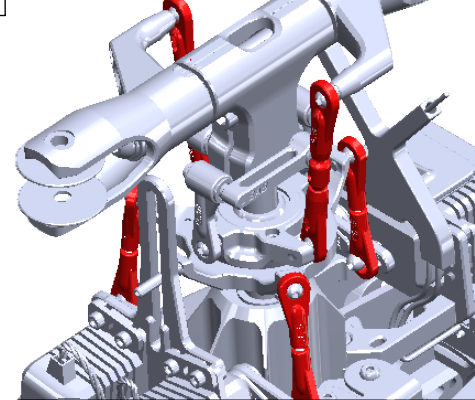

8 Check tail pulley set screws: Ensure they are tight. (It is suggested use a bit of Green Loctite.)

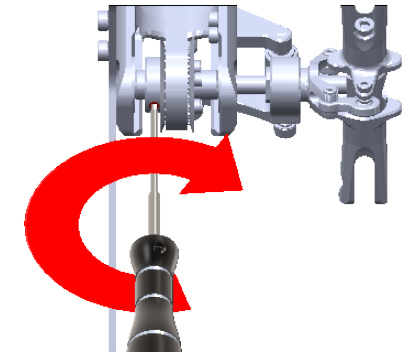

9 Check for vertical play of the main shaft.

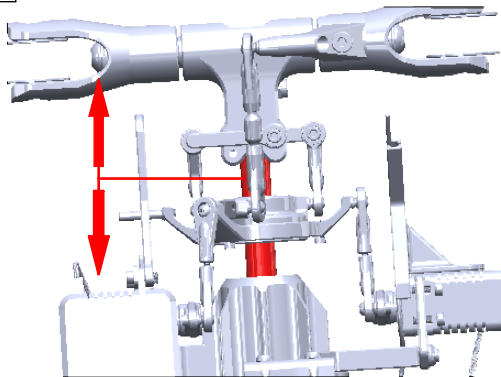

10 Check if the FBL-RX connectors are OK (hot glue is recommended).

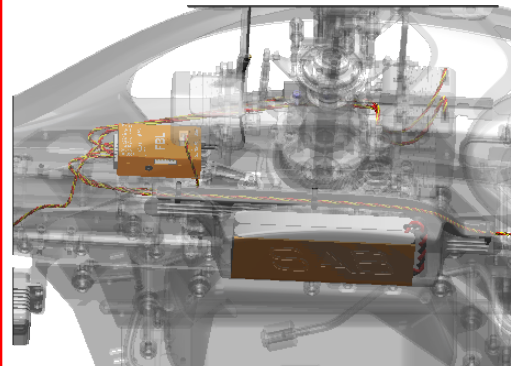

11 Check the M2.5 bell crank: Belt crank movement must be smooth and the screw locked. (It is suggested use a bit of Green Loctite.)

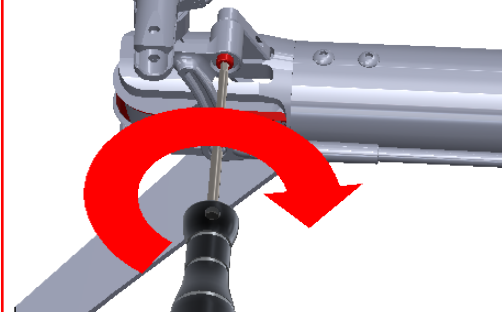





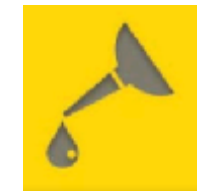







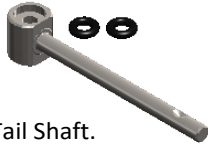

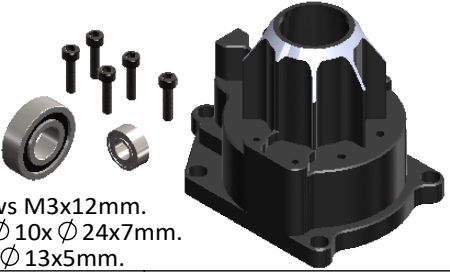
12 Be sure the follow parts are properly lubricated

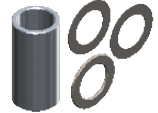
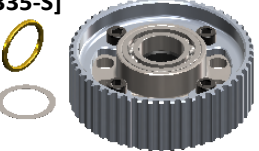
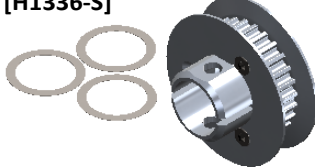
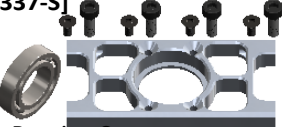
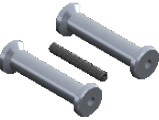
- *Main shaft/swashplate
- *Tail slider/tail shaft
- *Carbon rod/carbon rod support
- *All thrust bearings
- *All plastic balls connections

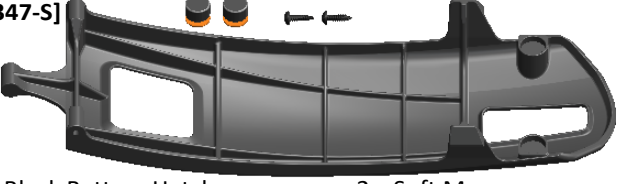

<p>Finishing Washer M3 [H0007-S]</p>  <p>- 10 x Finishing Washers M3.</p>	<p>Spacer [H0062-S]</p>  <p>- 4 x Spacer $\varnothing 7x \varnothing 9x0,5mm$.</p>	<p>Uniball M2 5H6 [H0064-S]</p>  <p>- 5 x Uniballs M2. - 5 x Uniball Spacers. - 5 x Head Cap Screws M2x8. - 5 x Head Cap Screws M2x6.</p>	<p>Uniball M3x4 5H3 [H0065-S]</p>  <p>- 5 x Uniballs M3x4 5H3.5.</p>	<p>Plastic Ball Link [H0066-S]</p>  <p>- 10 x Plastic Ball Link.</p>	<p>Servo Spacer [H0075-S]</p>  <p>- 10 x Servo Spacers.</p>
<p>Radius Arm HPS [H0204BM-S]</p>  <p>- 2 x Radius Arm. - 2 x Spacer Arm 2.5x4x6.3. - 2 x Spacer Arm 2.5x4x3mm. - 2 x Uniball Radius Arm.</p>	<p>Radius Plastic Arm [H0205-S]</p>  <p>- 2 x Radius Plastic Arm.</p>	<p>Radius Plastic Arm [H0205-S]</p>  <p>- 2 x Radius Plastic Arm.</p>	<p>Spacer [H0219-S]</p>  <p>- 2 x Spacer $\varnothing 4x \varnothing 6,9x0,5mm$.</p>	<p>Tail Spindle [H0220-S]</p>  <p>- 1 x Tail Spindle. - 2 x Head Cap Screws M3x6.</p>	<p>Finishing Washer M2.5 [H0255-S]</p>  <p>- 10 x Finishing Washer M2.5.</p>
<p>Plastic Tail Linkage [H0261-S]</p>  <p>- 2 x Plastic Tail Linkage. - 2 x Grip Link Bushing. - 2 x Head Cap Screws M2x6.</p>	<p>Servo Block [H0392-S]</p>  <p>- 8 x Servo Block. - 8 x Servo Spacer. - 16 x Head Screws M2.5x10.</p>	<p>Plastic Ball Link [H0403-S]</p>  <p>- 5 x Plastic Ball Link.</p>	<p>Uniball [H0538-S]</p>  <p>- 5 x UniBall.</p>	<p>Plastic Fan Case SET [H0662-S]</p>  <p>- 1 x Plastic Fan Case Left. - 1 x Plastic Fan Case Right. - 4 x Finishing Washer M3. - 4 x Head Cap Screws M3x10mm. - 5 x Head Cap Screws M2.5x10mm.</p>	
<p>Engine Mount [H0665-S]</p>  <p>- 1 x Engine Mount Left. - 1 x Engine Mount Right.</p>	<p>Engine Shaft YS [H0668-A-S]</p>  <p>- 1 x Engine Shaft YS.</p>	<p>Engine Shaft OS [H0668-B-S]</p>  <p>- 1 x Engine Shaft OS.</p>	<p>Steel Clutch [H0670-S]</p>  <p>- 1 x Steel Clutch. - 2 x Button Cap Screw M4x8.</p>	<p>Aluminum Engine Fan [H0671BM-S]</p>  <p>- 1 x Aluminum Engine Fan. - 4 x Flat Head Cap M3x8mm.</p>	<p>Aluminum Clutch Support [H0672-S]</p>  <p>- 1 x Aluminum Clutch Support.</p>
<p>Aluminum Clutch Bell [H0674BL-S]</p>  <p>- 1 x Clutch Bell. - 1 x Clutch Line.</p>		<p>Aluminum Engine Pulley 26T to 28T [H0675BL-26-28-S]</p>  <p>- 1 x Z26 to Z28 Nitro Pulley. - 1 x Nitro Pulley Flange. - 3 x Radial Bearing $\varnothing 12x \varnothing 18x4mm$.</p>	<p>Engine Frame Spacer [H0678BM-S]</p>  <p>- 4 x Engine Frame Spacer. - 4 x Button Screw M3x6mm.</p>	<p>Engine Support Spacer [H0682-S]</p>  <p>- 2 x Engine Support Spacer. - 2 x Socket Screw M3x8mm. - 2 x Flat Screw M3x8mm.</p>	

<p>Servo Mount [H0251-S]</p> <p>- 6 x Servo Mount.</p>	<p>SAB Fuel Sucker [H0705-S]</p> <p>- 1 x Fuel Clunk. - 1 x Tube $\varnothing 2.4 \times \varnothing 4.5 \times 106$. - 1 x Filter $\varnothing 6 \times \varnothing 13.5 \times 15$mm.</p>	<p>SAB Fuel Nipple [H0708-S]</p> <p>- 1 x Fuel Nipple. - 1 x Fuel Rubber 60 Shore.</p>	<p>SAB Fuel Stop [H0715-S]</p> <p>- 2 x SAB Fuel Stop. - 2 x T Connector.</p>	<p>Main Linkage [H0722-S]</p> <p>- 2 x Main Linkage. - 4 x Plastic Uniball.</p>	
<p>Reference Pin [H1048-S]</p> <p>- 1 x Reference Pin.</p>	<p>Tensioner Idler [H1066-S]</p> <p>- 1 x Tail Belt Idler. - 1 x Bushing. - 2 x Flanged Bearing $\varnothing 3 \times \varnothing 8 \times 3$ - 1 x Washer.</p>	<p>Wire Cover [H1107-S]</p> <p>- 1 x Wire Cover. - 1 x Finishing Washer M3. - 1 x Socket Screws M3x8mm. - 2 x Button Screws M2.5x6mm.</p>	<p>Antena Cover [H1134-S]</p> <p>- 1 x Antena Cover. - 1 x Double Side Tape.</p>	<p>Blade Grips Arm [H1202-S]</p> <p>- 2 x Blade Grips Arm. - 2 x Uniball M3. - 2 x Socket Screw M4x8.</p>	<p>Swashplate [H1204-S]</p> <p>- 7 x Uniball M3. - 1 x Reference Pin. - 1 x Swashplate Assembly.</p>
<p>Rear Servo Support [H1206-S]</p> <p>- 1 x Rear Servo Support. - 2 x Socket Screws M3x8mm.</p>	<p>Rear Servo Mount [H1207-S]</p> <p>- 1 x Rear Servo Mount. - 2 x Servo Spacer. - 2 x Finishing Washer M2.5. - 2 x Socket Screw M2.5x8mm.</p>	<p>Main Gear [H1208-S]</p> <p>- 1 x Main Gear. - 1 x Bushing. - 1 x Shoulder Screw M4x30. - 1 x Spacer $\varnothing 10 \times \varnothing 16 \times 1$mm. - 2 x Shim $\varnothing 10 \times \varnothing 16 \times 0.2$mm.</p>	<p>Serial Number [H1212-S]</p> <p>- 1 x Serial Number. - 1 x Flat Screw M2.5x5mm.</p>	<p>Damper [H1216-S]</p> <p>- 2 x Damper A. - 2 x Damper B. - 4 x Oring 70° - 2 x Damper C. - 4 x Oring 90°</p>	
<p>Front Servo Mount [H1217-S]</p> <p>- 1 x Front Servo Mount. - 4 x Servo Spacer. - 3 x Socket Screws M2.5x8mm.</p>	<p>Tail Blade Grips [H1233-S]</p> <p>- 2 x Tail Blade Grip. - 4 x Bearing $\varnothing 4 \times \varnothing 9 \times 2.5$mm. - 2 x Spacer $\varnothing 7 \times \varnothing 9 \times 0.5$mm. - 2 x Thrust Bearing $\varnothing 4 \times \varnothing 9 \times 4$mm. - 2 x Socket Screw M3x6mm. - 2 x Socket Screw M2x6mm.</p>	<p>Landing Gear Rod [H1242-S]</p> <p>- 2 x Landing Gear Rod. - 4 x Plug.</p>	<p>Tail Pitch Slider [H1249-S]</p> <p>- 1 x Tail Pitch Slider Assembled. - 2 x Slider Linkage. - 2 x Socket Screws M2x6mm. - 2 x Spacer.</p>		
<p>Spindle [H1263-S]</p> <p>- 2 x Spindle. - 2 x Button Screws M6x10mm. - 2 x Washer.</p>	<p>FBL/RX Support [H1237-S]</p> <p>- 1 x FBL Support. - 1 x FBL Plate. - 1 x RX Plate. - 4 x RX Plate. - 4 x Rubber. - 4 x Flat Screw M3x5mm. - 4 x Flat Screw M3x10mm. - 3 x Socket Screw M3x6mm.</p>	<p>Base Tail Belt Tensioner [H1278-S]</p> <p>- 1 x Bushing. - 1 x Base Tail Belt Tensioner. - 1 x Tensioner Column. - 1 x Tensioner Spring. - 1 x Shoulder Screw M3x22. - 2 x Flanged Bearing $\varnothing 3 \times \varnothing 7 \times 3$.</p>	<p>Center Hub [H1280-S]</p> <p>- 1 x Center Hub. - 1 x Nylon Nut M4. - 1 x Socket Screw M4x20mm. - 2 x Socket Screw M3x12mm.</p>	<p>Tail Case Group [H1306-S]</p> <p>- 1 x Tail Case Group. - 4 x Button Screw M3x4mm. - 2 x F_Bearing $\varnothing 5 \times \varnothing 13 \times 4$.</p>	

<p>Carbon Rod Support [H1310-S]</p>  <ul style="list-style-type: none"> - 1 x Carbon Rod Support. - 1 x Socket Screw M2.5x12. 	<p>Tail Pulley 22T [H1312-22-S]</p>  <ul style="list-style-type: none"> - 1 x Tail Pulley 23T. - 1 x Set Screw M3x6mm. 	<p>Tail Shaft [H1313-S]</p>  <ul style="list-style-type: none"> - 1 x Tail Shaft. - 1 x Tail Hub. - 2 x Oring. 	<p>Bell Crank Base [H1314-S]</p>  <ul style="list-style-type: none"> - 1 x Bell Crank Base. - 1 x Socket Screw M2.5x8mm. 	<p>Main Shaft [H1330-S]</p>  <ul style="list-style-type: none"> - 1 x Main Shaft. - 1 x Shoulder Screw M4x30. - 1 x Bushing. - 2 x Shim $\varnothing 10x \varnothing 16x0.2mm$. 	
<p>Top Case [H1331-S]</p>  <ul style="list-style-type: none"> - 1 x Main Case. - 5 x Socket Screws M3x12mm. - 1 x Bearing 2Rs $\varnothing 10x \varnothing 24x7mm$. - 1 x Bearing $\varnothing 6x \varnothing 13x5mm$. 		<p>Main Structure [H1332-S]</p>  <ul style="list-style-type: none"> - 1 x Main Structure. - 2 x Pin 3x6. - 1 x Bearing $\varnothing 10x \varnothing 22x6mm$. - 1 x Bearing 2RS $\varnothing 12x \varnothing 24x6$. 		<p>Pinion [H1333-S]</p>  <ul style="list-style-type: none"> - 1 x Pinion. - 2 x Shim $\varnothing 6x \varnothing 9 x 0.2mm$. 	<p>Gear Bushing [H1334-S]</p>  <ul style="list-style-type: none"> - 1 x Gear Bushing. - 2 x Shim $\varnothing 10x \varnothing 16x0.2mm$. - 1 x Washer $\varnothing 10x \varnothing 16x1mm$.
<p>Main Pulley [H1335-S]</p>  <ul style="list-style-type: none"> - 1 x Main Pulley SET. - 1 x Bushing. - 1 x Shim $\varnothing 12x \varnothing 16x0.1mm$. 	<p>Front Tail Pulley [H1336-S]</p>  <ul style="list-style-type: none"> - 1 x Front Tail Pulley SET. - 3 x Shim $\varnothing 12x \varnothing 16x0.1mm$. 	<p>Bearing Support [H1337-S]</p>  <ul style="list-style-type: none"> - 1 x Bearing Support. - 1 x Bearing $\varnothing 12x \varnothing 21x5mm$. - 4 x Socket Screw M3x8mm. - 4 x Flat Screw M2.5x5mm. 	<p>Tank Column [H1338-S]</p>  <ul style="list-style-type: none"> - 2 x Tank Column. - 1 x Set Screw M3x20. 	<p>Carbon Tail Boom [H1339-S]</p>  <ul style="list-style-type: none"> - 1 x Carbon Tail Boom. 	
<p>Frame Spacer [H1340-S]</p>  <ul style="list-style-type: none"> - 8 x Frame Spacer. 	<p>Tail Belt Idler Mount [H1341-S]</p>  <ul style="list-style-type: none"> - 1 x Tail Belt Idler Mount. - 2 x Socket Screw M3x12mm. - 2 x Shim $\varnothing 3x \varnothing 6x0.5mm$. 	<p>LOWER Main Frame [H1344-S]</p>  <ul style="list-style-type: none"> - 1 x LOWER Main Frame. - 1 x Green Sticker. 		<p>Black Battery Hatch [H1347-S]</p>  <ul style="list-style-type: none"> - 1 x Black Battery Hatch. - 2 x Soft Mousse. - 2 x Tapping Screws M3x10mm. - 2 x Double Side Tape. 	
<p>Canopy Spacer [H1348-S]</p>  <ul style="list-style-type: none"> - 1 x Canopy Spacer. - 2 x Flat Screws M2.5x8mm. - 2 x Nylon Nut M3. 	<p>Boom Mount Support [H1350-S]</p>  <ul style="list-style-type: none"> - 1 x Boom Mount Support. - 4 x Finishing Washer M3. - 4 x Socket Screws M3x10. 		<p>Tail Servo Mount [H1353-S]</p>  <ul style="list-style-type: none"> - 1 x Tail Servo Mount. - 2 x Socket Screw M3x12mm. 	<p>CF Low Side Frame Front [H1358-S]</p>  <ul style="list-style-type: none"> - 2 x Set Sticker. - 2 x CF Low Side Frame Front. 	

<p>Main Frame [H1359-S]</p>  <p>- 1 x Main Frame.</p>	<p>Front Boom Block [H1304-S]</p>  <p>- 1 x Front Boom Block. - 2 x Socket Screws M3x10. - 1 x Socket Screw M3x12. - 1 x Nylon Nut M3.</p>	<p>Boom Block [H1372-S]</p>  <p>- 1 x Boom Block. - 2 x Socket Screws M3x10. - 1 x Socket Screw M3x12. - 1 x Nylon Nut M3.</p>	<p>Block NUT M3 [H1386-S]</p>  <p>- 5 x Block NUT M3. - 5 x Nylon NUT M3.</p>	<p>Tail Bell Crank Lever [H1393-S]</p>  <p>- 1 x Uniball M2. - 1 x Uniball M3. - 1 x Bell Crank Lever Assembled. - 1 x Socket Screws M2.5x18mm. - 1 x Socket Screws M2x6mm.</p>
<p>Tail Boom Tension [H1402-S]</p>  <p>- 1 x Clamp 1. - 1 x Clamp 2. - 1 x Derlin. - 1 x Oring. - 1 x Nylon Nut M3. - 1 x Set screws M3x20mm. - 1 x Shoulder Screw M3x18mm. - 2 x Socket Screws M4x10mm.</p>	<p>Plastic Landing Gear [H1407-S]</p>  <p>- 2 x Plastic Landing Gear. - 4 x Set Screws M4x4mm.</p>	<p>Alu Landing Gear Mount [H1408-S]</p>  <p>- 2 x Alu Landing Gear Mount. - 8 x Socket Screws M2.5x8mm.</p>	<p>Main Blade Grips [H1411-S]</p>  <p>- 2 x Blade Grip. - 4 x Bearing $\phi 8 \times \phi 14 \times 4 \text{mm}$. - 2 x Thrust Bearing $\phi 8 \times \phi 14 \times 4 \text{mm}$. - 2 x Washer $\phi 11 \times \phi 13.5 \times 0.5 \text{mm}$. - 2 x Button Screws M4x10mm.</p>	
<p>Tank [H1412-S]</p>  <p>- 1 x Tank. - 3 x Bushing. - 6 x Rubber Washer.</p>	<p>Canopy RAW NITRO [H1424-S]</p>  <p>- 1 x Canopy Raw Nitro. - 2 x Double Side Tape. - 2 x Spacer 3.1x12x1.8. - 4 x Finishing Washer M3. - 2 x Socket Screws M3x10mm. - 2 x Socket Screws M3x12mm.</p>	<p>Plastic Wire Cover [H1444-S]</p>  <p>- 1 x Plastic Wire Cover. - 1 x G10 Wire Cover - 2 x Washer M3. - 2 x Socket Screws M3x14mm.</p>		
<p>[H1502-S]</p>  <p>- 4 x Main Blade Washer.</p>	<p>[HA016-S]</p>  <p>- 1 x Wrench Nut M8.</p>	<p>[HA035-S]</p>  <p>- 2 x Double side tape 30x100x1.</p>	<p>[HA043-S]</p>  <p>- 1 x Blade Holder.</p>	<p>[HA044-S]</p>  <p>- 2 x Strap 16x205mm.</p>
<p>[HA045-S]</p>  <p>- 2 x Velcro Tape 36 x 100mm.</p>	<p>[HA050-S]/[HA051-S]</p>  <p>- 4 x Servo Horn.</p>	<p>[HA075-S]</p>  <p>- 1 x Free Wheel Clutches grease.</p>	<p>[HA076-S]</p>  <p>- 1 x Tranmissions module grease.</p>	

<p>[HC004-S]</p> <p>- 8 x Socket Head Cap Screws M2x6mm.</p>	<p>[HC008-S]</p> <p>- 8 x Socket Head Cap Screws M2x8mm.</p>	<p>[HC018-S]</p> <p>- 8 x Socket Head Cap Screws M2.5x8mm.</p>	<p>[HC019-S]</p> <p>- 8 x Button Head Cap Screws M2.5x6mm.</p>	<p>[HC020-S]</p> <p>- 8 x Socket Head Cap Screws M2.5x8mm.</p>	<p>[HC022-S]</p> <p>- 8 x Socket Head Cap Screws M2.5x10.</p>	<p>[HC026-S]</p> <p>- 8 x Socket Head Cap Screws M2.5x12.</p>	<p>[HC032-S]</p> <p>- 8 x Socket Head Cap Screws M2.5x18.</p>
<p>[HC038-S]</p> <p>- 8 x Button Head Cap Screws M3x4mm.</p>	<p>[HC044-S]</p> <p>- 8 x Socket Head Cap Screws M3x6mm.</p>	<p>[HC050-S]</p> <p>- 8 x Socket Head Cap Screws M3x8mm.</p>	<p>[HC056-S]</p> <p>- 8 x Socket Head Cap Screws M3x10mm.</p>	<p>[HC062-S]</p> <p>- 8 x Socket Head Cap Screws M3x12mm.</p>	<p>[HC064-S]</p> <p>- 8 x Socket Head Cap Screws M3x14mm.</p>	<p>[HC068-S]</p> <p>- 8 x Socket Head Cap Screws M3x16mm.</p>	<p>[HC074-S]</p> <p>- 2 x Socket Shoulder Screws M3x16. - 2 x Nylon Nut M3.</p>
<p>[HC079-S]</p> <p>- 2 x Socket Shoulder Screws M3x18. - 2 x Nylon Nut M3.</p>	<p>[HC086-S]</p> <p>- 8 x Socket Head Cap Screws M3x22mm.</p>	<p>[HC094-S]</p> <p>- 8 x Button Head Cap Screws M3x6mm.</p>	<p>[HC098-S]</p> <p>- 8 x Button Head Cap Screws M4x8mm.</p>	<p>[HC102-S]</p> <p>- 8 x Socket Head Cap Screws M4x10mm.</p>	<p>[HC103-S]</p> <p>- 8 x Socket Head Cap Screws M4x15mm.</p>	<p>[HC104-S]</p> <p>- 8 x Socket Head Cap Screws M4x22mm.</p>	<p>[HC111-S]</p> <p>- 8 x Socket Shoulder Screws M4x24.</p>
<p>[HC122-S]</p> <p>- 8 x Button Head Cap Screws M6x10mm.</p>	<p>[HC125-S]</p> <p>- 8 x Flat Head Cap Screws M2.5x8mm.</p>	<p>[HC128-S]</p> <p>- 8 x Flat Head Cap Screws M2.5x5mm.</p>	<p>[HC132-S]</p> <p>- 8 x Flat Head Cap Screws M3x5mm.</p>	<p>[HC134-S]</p> <p>- 8 x Flat Head Cap Screws M3x8mm.</p>	<p>[HC135-S]</p> <p>- 8 x Flat Head Cap Screws M3x10mm.</p>	<p>[HC136-S]</p> <p>- 8 x Tapping Head Cap Screws M3x10mm.</p>	<p>[HC140-S]</p> <p>- 8 x Set Screws M2.5x18.</p>
<p>[HC144-S]</p> <p>- 8 x Set Screws M3x6.</p>	<p>[HC150-S]</p> <p>- 8 x Set Screws M2.5x20.</p>	<p>[HC152-S]</p> <p>- 8 x Set Screws M4x4.</p>	<p>[HC153-S]</p> <p>- 8 x Set Screws M4x6.</p>	<p>[HC176-S]</p> <p>- 5 x Washer $\varnothing 3 \times \varnothing 4 \times 0.5 \text{mm.}$</p>	<p>[HC180-S]</p> <p>- 5 x Washer $\varnothing 3.2 \times \varnothing 6 \times 0.5 \text{mm.}$</p>	<p>[HC193-S]</p> <p>- 5 x Washer $\varnothing 6 \times \varnothing 12 \times 1 \text{mm.}$</p>	<p>[HC197-S]</p> <p>- 8 x Nylon Nut M2.</p>
<p>[HC206-S]</p> <p>- 8 x Nylon Nut M3.</p>	<p>[HC212-S]</p> <p>- 8 x Nylon Nut M4.</p>	<p>[HC230-S]</p> <p>- 5 x Washer $\varnothing 10 \times \varnothing 16 \times 1 \text{mm.}$</p>	<p>[HC232-S]</p> <p>- 5 x Washer $\varnothing 10 \times \varnothing 16 \times 0.2 \text{mm.}$</p>	<p>[HC242-S]</p> <p>- 3 x Thread Rod M2.5x40mm.</p>	<p>[HC243-S]</p> <p>- 2 x Thread Rod M2x64mm.</p>	<p>[HC477-S]</p> <p>- 1 x Tail Belt 2004mm.</p>	<p>[HC330-S]</p> <p>- 4 x Oring Damper.</p>

<p>[HC400-S]</p>  <p>- 4 x Flanged Bearing Ø 2.5x Ø 6x2.6mm .</p>	<p>[HC402-S]</p>  <p>- 4 x Flanged Bearing Ø 3x Ø 7x3mm .</p>	<p>[HC403-S]</p>  <p>- 4 x Ball Bearing Ø 4x Ø 9x2.5mm .</p>	<p>[HC412-S]</p>  <p>- 4 x Flanged Bearing Ø 5x Ø 13x4mm .</p>	<p>[HC416-S]</p>  <p>- 2 x Flanged Bearing Ø 7x Ø 11x2.5mm .</p>	<p>[HC417-S]</p>  <p>- 2 x Ball Bearing Ø 8x Ø 14x4mm .</p>	<p>[HC424-S]</p>  <p>- 2 x Ball Bearing Ø 12x Ø 21x5mm .</p>	<p>[HC425-S]</p>  <p>- 2 x Ball Bearing Ø 12x Ø 18x4mm .</p>
<p>[HC434-S]</p>  <p>- 2 x Thrust Bearing Ø 4x Ø 9x4mm .</p>	<p>[HC437-S]</p>  <p>- 2 x Thrust Bearing Ø 8x Ø 14x4mm.</p>	<p>[HC473-S]</p>  <p>- 1 x Tube Ø 2,5x Ø 5,5x1m.</p>	<p>[HC474-S]</p>  <p>- 1 x Tube Ø 2,5x Ø 4,5x1m.</p>	<p>[HC479-S]</p>  <p>- 2 x Ball Bearing Ø 10x Ø 22x6mm .</p>	<p>[HC485-S]</p>  <p>- 4 x Flanged Bearing Ø 3x Ø 8x3mm .</p>	<p>[HC545-S]</p>  <p>- 8 x Head Cap Screw Shoulder M4x21.5.</p>	<p>[HC582-S]</p>  <p>- 8 x Head Cap Screw Special M4x8mm.</p>
<p>[HC587-S]</p> <ul style="list-style-type: none"> - 1 x Alu Bushing. - 1 x Ball Bearing Ø10xØ24x7mm. - 1 x Ball Bearing 10 x 22 x 6 mm. - 1 x Ball Bearing 2RSØ10xØ22x6. - 1 x Ball Bearing 2RSØ10xØ24x6. 			<ul style="list-style-type: none"> - 2 x Pin 3x6mm. - 1 x Head Cap Shoulder M4x30. - 1 x Bushing. - 1 x Shim Ø6xØ9x0.2mm. - 1 x Ball Bearing Ø6xØ13x5mm. - 2 x Shim Ø10xØ16x0.2mm. - 1 x Washer Ø10 x Ø16 x 1mm. 			<p>[HC598-S]</p>  <p>- 4 x Oring Damper.</p>	<p>[HC602-S]</p>  <p>- 1 x One Way Bearing Ø 12x Ø 20x12mm.</p>
<p>[HC619-S]</p>  <ul style="list-style-type: none"> - 1 x Carbon Rod Ø 3x Ø 4x691mm - 2 x Plastic Ball Linkage - 1 x Brass Tube. - 2 x Thread Rod M2.5x40. - 2 x Aluminum Bush. 		<p>[HC608-S]</p>  <p>- 8 x Head Cap Screw M3x25mm.</p>	<p>[HA081-S]</p>  <ul style="list-style-type: none"> - 2 x Rubber Washer. - 14 x Double side tape. 	<p>[HC617-S]</p>  <p>- 1 x Engine Belt GT3-309-13 mm.</p>			
<p>[690-TBS]</p>  <p>- 2 x Main Blades 690mm.</p>						<p>[105-TBS]</p>  <p>- 2 x Tail Blades 105mm.</p>	



Carefully check your model before each flight to ensure it is airworthy.

Consider flying only in areas dedicated to the use of model helicopters.

Check and inspect the flying area to ensure it is clear of people and obstacles.

Rotor blades can rotate at very high speeds! Be aware of the danger they pose.

Always keep the model at a safe distance from other pilots and spectators.

Avoid maneuvers with trajectories towards a crowd.

Always maintain a safe distance from the model.

GOBLIN RAW NITRO

Release 1.0 - July 2021

WORLD DISTRIBUTION

www.goblin-helicopter.com

For sales inquiries, please email:

sales@goblin-helicopter.com

For info inquiries, please email:

support@goblin-helicopter.com

Attention: If you are a customer and have questions or need of assistance, please contact in a first time the Goblin retailer where you made the purchase.

EUROPEAN DISTRIBUTION

www.sabgroup.it

For sales inquiries, please email:

sale@sabgroup.it

For info inquiries, please email:

support@sabgroup.it

Attention: If you are a customer and have questions or need of assistance, please contact in a first time the Goblin retailer where you made the purchase.

WWW.GOBLIN-HELICOPTER.COM

SAB



SAB HELI DIVISION